

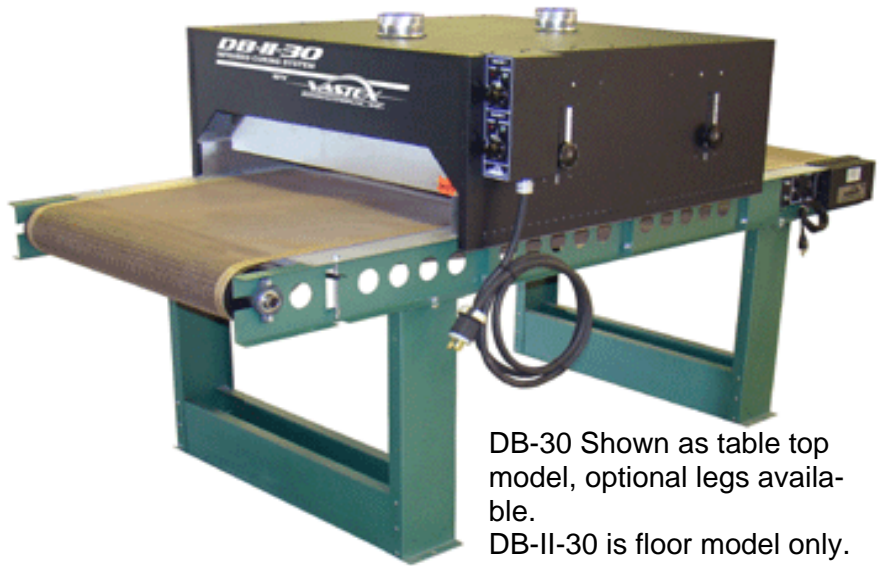

DB-30 & DB-II-30

Conveyor Drying System Assembly & Operating Manual



DB-30 Shown as table top model, optional legs available.
DB-II-30 is floor model only.

	Pg #
• Introduction / Safety	2
• Assembly	4-5
• Component Identification	6-7
• Operation	8
• Maintenance	9
• Troubleshooting	10
• Dryer & Exhaust Hood Ducting	11
• Installation: Conveyor Belt Covers	12
• Warranty / Terms & Conditions	13-14

Vastex International, Inc.
 1032 N. Irving St.
 Allentown, Pa. 18109 USA
 Phone# 610 434-6004 Fax# 610 434-6607
 Web Site www.vastex.com

Authorized Representative in Europe:
 Certification Experts BV
 Nieuwstad 100 1381 CE Weesp,
 The Netherlands
 Tel : + 31 (0) 294 – 48 33 55

Vastex E-mail assistance

Purchasing & Product Info:
sales@vastex.com
 Electrical Support:
stech@vastex.com
 Tech Support, Mechanical Setup, and Operation:
techsupport@vastex.com
 Screen Printing Issues & Support:
printech@vastex.com

Electrical Drawing #: _____ Rev: _____

Serial Number: VTX _____ Date: ___/___/___

(Please log your machine's serial number and date of purchase for future reference.)

Introduction

Congratulations, you have chosen a VASTEX conveyor curing system. VASTEX has been designing and building dryers since 1960 and has the knowledge and expertise to supply a quality dryer and help you keep it running for years to come. VASTEX has innovated many of the features found in conveyor ovens today from control methods, modular features, air movements and belt tracking.

Your Vastex Infrared Dryer has been Factory tested and burned in for a period of 2-8 hours. All components

Safety

The Instruction Manual and Safety Instructions must be read and understood by anyone operating the Vastex Conveyor Drying System.

- The operator should read and understand the instruction manual before operating this equipment. Store instruction manual and safety instructions near equipment for easy access to operators.
- VASTEX Conveyor Drying System is intended for the curing of non-flammable inks on screen printed materials. Do not use for any other purpose unless authorized by Vastex International, Inc. Use of this equipment for any other purpose can be dangerous and may cause damage to this equipment, voiding the warranty.
- It is recommended that the area around this equipment be designated as a work area and only authorized employees be allowed in the area.
- Children and pets must be kept clear of the work area.
- Do not place any objects on top of the drying chamber. Surfaces are hot!
- Never leave equipment unattended.
- Do not operate conveyor or dryer with any cover or guard removed.
- Operator must be familiar with controls of the dryer and conveyor.
- Never put excessive load on the conveyor belt.
- Before starting production, the operator must check that all covers and guards are in place, no material has been left on the conveyor, and the work area is clear of obstructions.
- Switch on and verify conveyor belt is moving before turning on the heat.
- Allow dryer to cool to 300°F (149°C) before switching off conveyor.
- Always turn off power at the main disconnect at the end of production.
- In case an abnormal symptom occurs, for example excessive vibration, noise, and strong smell or smoke development, turn off the VASTEX Conveyor Drying System and contact a qualified technician.
- Immediately turn off the VASTEX Conveyor Drying System if products become jammed in the drying chamber or conveyor belt.
- Do not remove any cover or guard until power at the main disconnect is switched off and locked out. No unauthorized persons are to be allowed inside the control boxes.
- Turn off and lock out power at the main disconnect before any cleaning or maintenance.
- Only qualified technicians should be allowed to make repairs on the VASTEX Conveyor Drying System.

Safety, continued

- **Noise and vibration:** This equipment does not produce noise in excess of 70 dB(A) at workstations.
- **Stability during use, transportation, assembly, dismantling when out of service, testing, and foreseeable breakdowns:** This equipment is designed and expected to be stable during all foreseeable conditions, so long as the procedures and instructions given in this manual are followed. When dryers are assembled onto legs, it is recommended that two or more people stand the unit upright after bolting legs on.

Safe handling, transport, and storage: Before storing the unit, follow the shutdown procedure on P. 8 to allow the heater assembly to cool properly. No special handling considerations are necessary, except to be aware of the weight of the equipment and take standard precautions for moving such weights:

DB-30:

Main Unit: 265 lbs (120.2 kg)

Optional Legs: 30 lbs (13.6 kg)

DB-II-30:

Main Unit: 465 lbs (210.9 kg)

Included Legs: 30 lbs (13.6 kg)

Optional locking casters are available for all DB-series dryers equipped with legs. When equipment is to be moved frequently, it is recommended that these be installed.

Assembly

Tools Needed: (2) 9/16" open end wrenches, (1) 7/16" open end wrench or socket, (1) 1/4" nut driver OR flat blade screw driver

- 1) The conveyors are assembled in the same way for all DB-Series dryers. The DB-30 is being used for the pictures. Remove the conveyor parts from skid and lay out on a large table or the floor as shown.

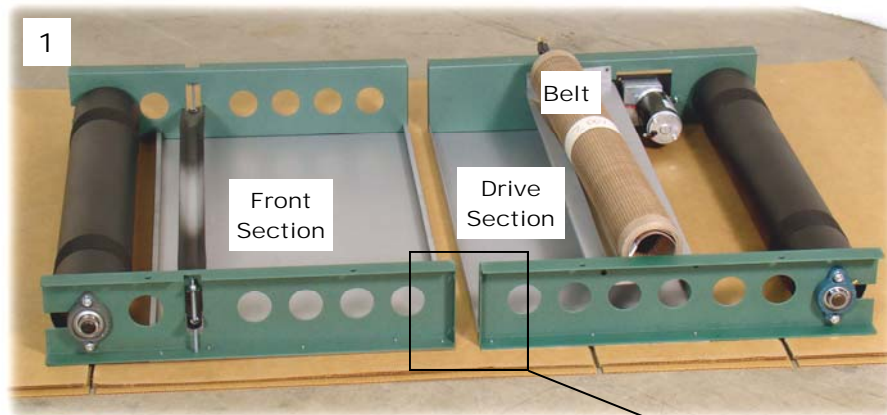

- 2) Bolt together all sections of the conveyor. Each section is bolted to the next using (2) 3/8"x 3/4" bolts, serrated locknuts. Photo on right.

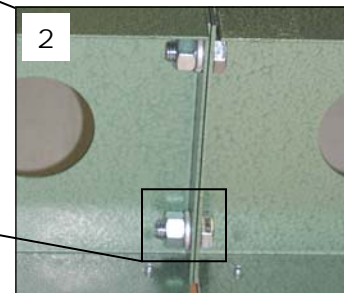
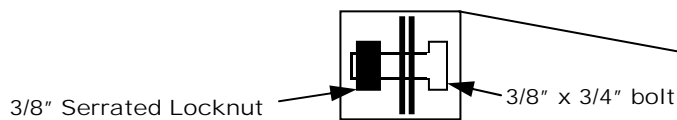

- 3) Install the (Optional) leg assemblies using (2) 3/8" x 3/4" bolts and serrated locknuts on each leg assembly.

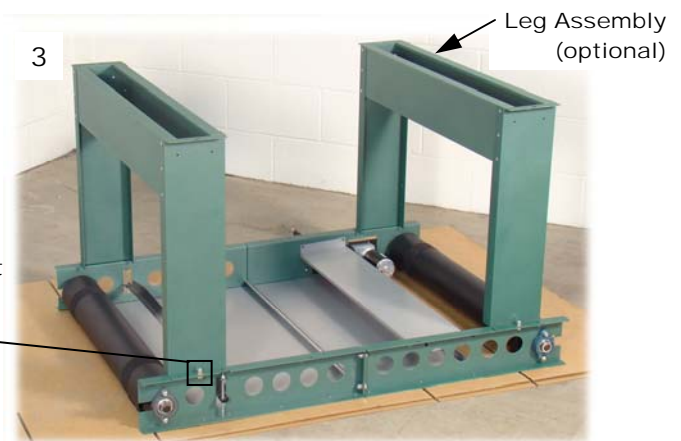
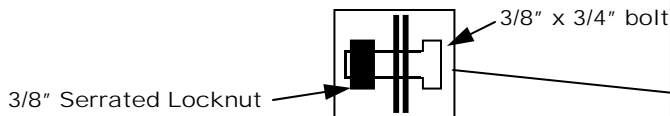

- 4) Turn the conveyor right side up. Install the chain guard with the (2) black #8 machine screws. See Maintenance section for chain adjustment

Chain Guard

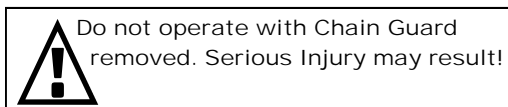

Assembly (cont'd)

5) The belt needs to be installed as shown in the diagram below. Be sure the belt is routed under the brace found near the gear motor. To connect your belt, align the Alligator Lace and install the pin. Some belts will have a plastic flap over the Alligator Lace. Position it as shown in the diagram.

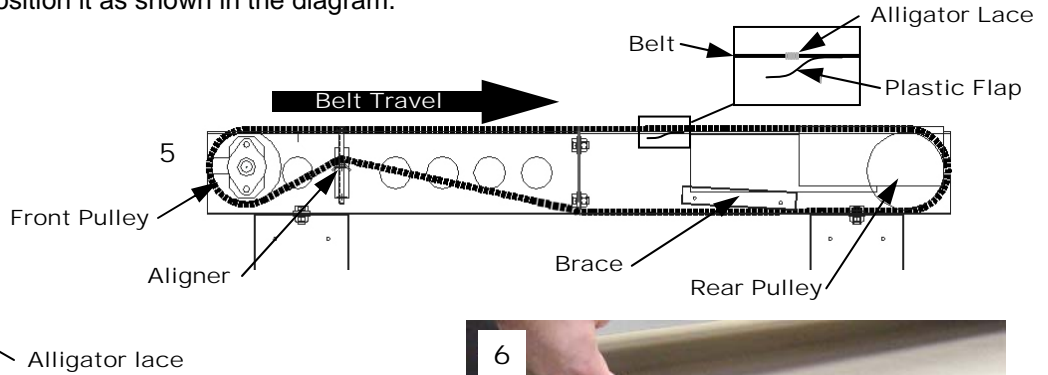
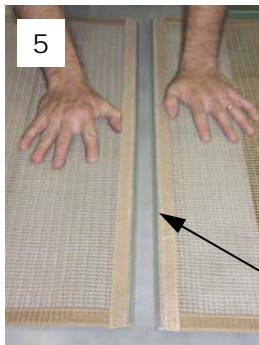

6) The belt needs to be tightened and adjusted. To tighten and adjust the belt, use the Aligner Bolts. To raise the Aligner, turn the Aligner Bolt clockwise with a 7/16" wrench. To lower it, turn it counter clockwise. Raise the Aligner until you have about 2"-2½" of slack as shown on right.

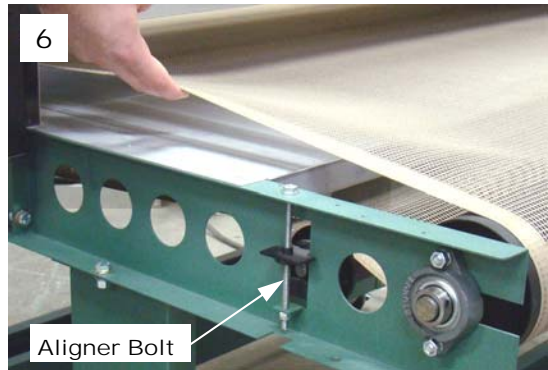

7) Install the three conveyor belt covers. See supplied document 01-01-014 for installation.

8) Place the Heat Chamber on the conveyor, centered between the belt's rollers, with the Control Panel on the right side.

9) Electrical Connections

Chamber: Refer to the wiring diagrams included with your dryer. Several combinations available.

Conveyor: Refer to plug diagrams on the Control page. Conveyors are available in either 120V or 240V
 120V, 1 Amp, 50/60Hz 240V, .5 Amp, 50/60Hz

10) Tracking the belt is the final step in setting up your Dryer. The belt speed should be turned up during belt tracking. The model below shows how to track the belt. Be sure to adjust the Aligner bolts at 1/4 turn at a time. The dryer should be on a flat surface for proper belt tracking.

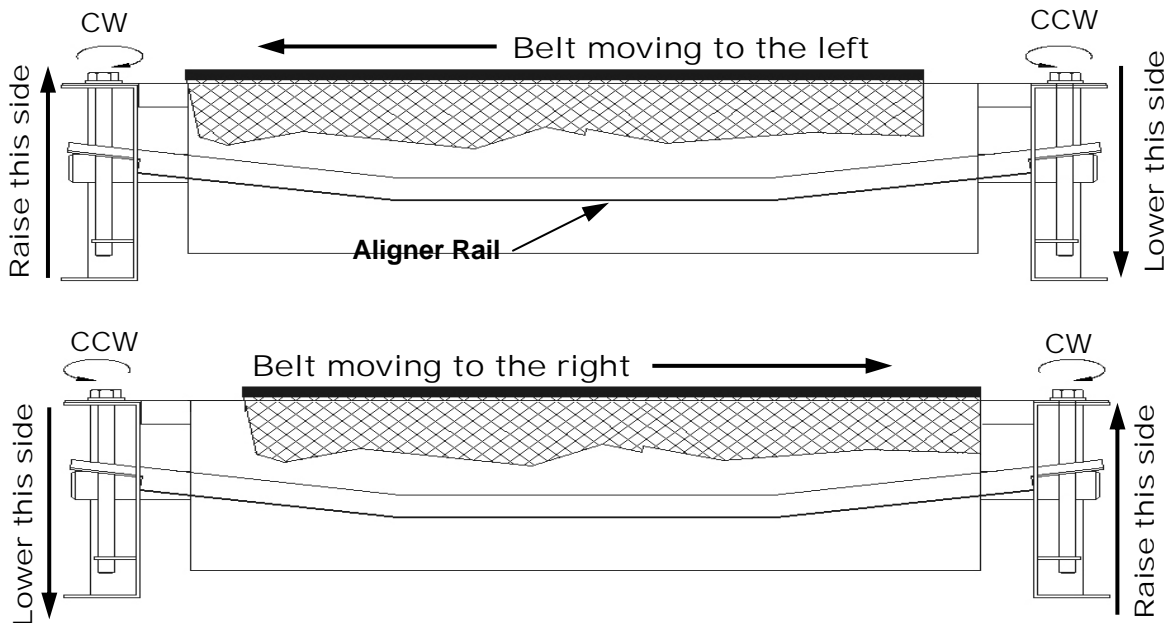

Component Identification



Chamber Components

- IR Heater** The infrared heaters in VASTEX dryers emit medium wave infrared heat, perfect for curing plastisol inks. The heater connections are located in the trough on the right side of the heater, connected with high temperature terminals and stainless steel socket head cap screws.
- Control Box** The Control Box houses the Variable Heat Control and a Heat Light.
- Exhaust Stack** 4" unpowered exhaust stack. (Optional) Exhaust booster can be added here to pull fumes out of the chamber and exhaust outside.

Conveyor Components

- Belt** The conveyor belt is made of Teflon coated fiberglass. It is joined together with an alligator lace using a steel pin to connect each side. The belt will not burn under normal conditions but the dryer should always have the belt moving while the heaters are above 300 degrees (149 deg. C). The belt should remain tracked in the center of each pulley. (See "Belt Installation and Tracking" for adjustment instructions.)
- Aligner** The aligner is a device for tracking the belt and keeping it on the pulley. As the belt moves from side to side the aligner is used for adjustments to keep it centered. The belt does not have to be perfectly centered on the pulley but should not be hanging over either edge.
- Pulley** The pulleys at either end of the conveyor are made by VASTEX of 4 ½ inch tubing with ¾ inch center shaft. They are mounted on self aligning flange bearing blocks for precision rolling.
- Gear Motor** A 90 Volt DC gear motor is located to the rear of the conveyor. It drives the rear pulley and belt with a roller and a #25 chain.

Controls

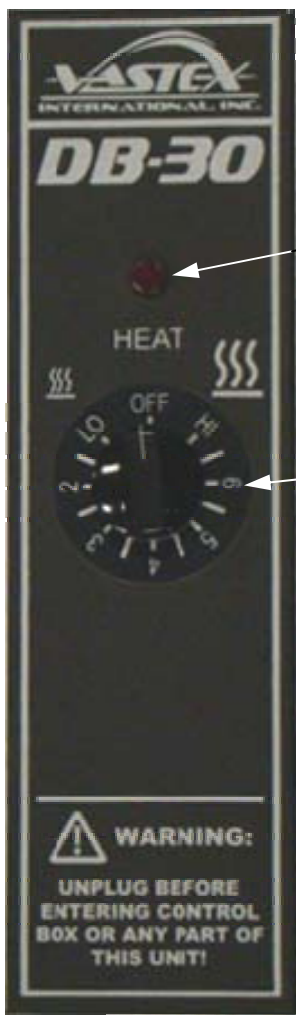

Heat on Light

This RED light is wired to the controller. It will illuminate when the control is turned on, even if the controller has failed.

Variable Heat Control

The control has positions LO-2-3-4-5-6 and HI. The controller turns the power to the heater on and off to vary the temperature. The higher the number on the controller the longer the on cycle and shorter the off cycle is. The HI position keeps the power on constantly.

Receptacle Configuration

The Diagrams below show the possible Receptacles needed for the conveyor and chamber of your DB-Series Dryer.

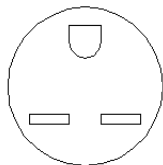

240 Volt 15 Amps
Nema 6-15R

DB-240, DB-30, DB-18-240
240 Volt "X"Series Conv.

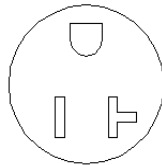

120 Volt 20 Amps
Nema 5-20R

DB-120, DB-18 &
DB-30-120

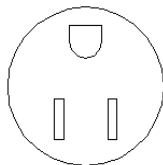

120 Volt 15 Amps
Nema 5-15R

120 Volt "X"Series Conv.
120 Volt Exhaust options
120 Volt Scrub Air

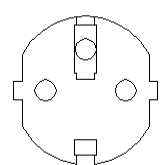

240 Volt 2.5 to 15 Amps
CEE 7/7

All Continental Europe
Machines under 16 amps

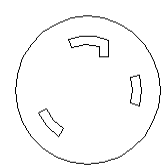

240 Volt 22 Amps
L6-30R

DB-II-18 & DB-II-30

Dryer Operation

Startup Procedure

- 1 Turn on Power** Be sure your breaker is in the off position and the dryer's dial controls are off. Plug the Conveyor and Chamber into their properly rated outlets and turn the breaker on.
- 2 Check belt path:** Remove any objects from the conveyor and belt.
- 3 Turn on Conveyor:** Set belt speed with the Belt Speed Control on the conveyor, near the motor.
- 4 Turn on the Heat:** Turn the Variable Heat Control dial on HI for 10-15 minutes to allow the dryer to warm up.



Curing Plastisol with infrared:

Plastisol ink can fully cure in approximately 20-30* seconds. The ink must achieve 310°-320° F (154°-160°C) to cure and fuse to the garment.

Discharge or water based: (A powered exhaust is recommended)

Water based products require more time than plastisol to cure due to the fact that the water/moisture must be evaporated before the ink can cure. We have seen cure times from 50 to 90* seconds to achieve a full cure or discharge and not damage the garment. Please note as the time is increased the temperature must be decreased to protect the garment from scorching.

***Actual cure times can vary depending on conditions such as garment moisture and color, ink color, ink thickness, and environmental conditions. All three variables should be used to maximize production while insuring a proper cure.**

- 5 Set the Heat:**  With the dryer plugged in, rotate the Variable Control Timer to the desired setting. Often times, it is best to run the dryer on HI and adjust your belt speed and heater height to achieve a proper cure.
- 6 Set the Heater Height:**  Set the desired heater height for your job. On each side of the heating chamber, there is a knob to raise and lower the heater. On DB-II models, there are (2) knobs on each side. It is recommended to run the heater height at about 2" - 3" above the garment. The heater can be run at an angle for curing non-flat substrates such as hats.
- 7 Set the Belt Speed:**  Rotate the Belt Speed Control Knob clockwise to increase speed and counter-clockwise to decrease it. For Plastisol inks, a good starting point is 20-25 seconds in the chamber. The dial numbers are for reference only. They do not represent seconds in the chamber.

Operation Tips

- While machine is in operation, it is necessary to have the belt moving while the heater is above 300°F (149°C).
- Allow approximately 15 minutes for dryer to reach Full temperature.
- If no garments are being run through the dryer for more than 10 minutes, it is recommended to lower the dryer to "4" or lower. It will take approximately 10 minutes to return to operating temperature.
- Periodically check ink temperature at the exit of the dryer. It is recommended that you check the temperature of the ink towards the outside of the printed image.
- When checking temperature with a laser gun, shoot the ink while it is still under the heating elements.

Shut Down Procedure

- 1 Turn off Heat:** Turn the Variable Control Timer off. Allow the heaters to cool for 10-15 minutes before shutting the conveyor off. Belt damage may result from stopping the conveyor with hot elements.
- 2 Turn off Conveyor:** Once the dryer cools down to 300°F (149°C) or lower, turn the Belt Speed down to the off position. Skip this step if leaving the conveyor belt speed set for the following shift.
- 3 Turn off Breaker:** Turn off the breakers controlling your DB-series dryers at the end of each shift and unplug them from their outlets.

Maintenance

Caution! Power must be turned off at the external disconnect, or the machine unplugged, before entering any part of this machine. A qualified electrician should perform any internal testing requiring power on!

- Electrical Connections** Electrical connections will loosen in time from heating and cooling. Every three (3) months the **power should be turned off** at the external disconnect, or unplugged, and all the points of connection should be inspected and tightened.
- Lint Buildup** As with your clothes dryer at home lint will build up where ever air is flowing over garments.
 - Every six months**
 - The top cover should be removed to clean around the heater and any other visible debris buildup.
 - Every 2-3 months**
 - The optional exhaust blower, located on the rear of the machine, should be cleaned. To open the back panel of the exhaust blower, remove the (14) black #8 machine screws for access to the blower.
- Motor Chain** Chains can loosen in time and should be inspected, adjusted, and lubricated when necessary. The motor chain is located in the rear of the conveyor behind the Chain Guard.

Drive Chain Adjustment

In order to **adjust the chain tension** or **remove the control assembly**, the chain guard must first be removed.

 **DO NOT RUN YOUR CONVEYOR WITHOUT THE CHAIN GUARD IN PLACE.**



Chain Guard

To remove the chain guard: Unfasten the two black sheet metal screws at the top. Be sure to replace the guard after adjustment is made.

To adjust the drive chain, loosen the (3) control assembly mounting screws. Adjust any slack out of conveyor chain and retighten screws.

Caution! Do not over tighten chain, damage to bearings may occur.



X-Series conveyor control assembly.
Model# XCB-DB-XXX
(XXX = 120 or 240 volt)

Caution:
With the control assembly removed there are open wires and electrical connections. Severe shock can occur if caution is not taken.

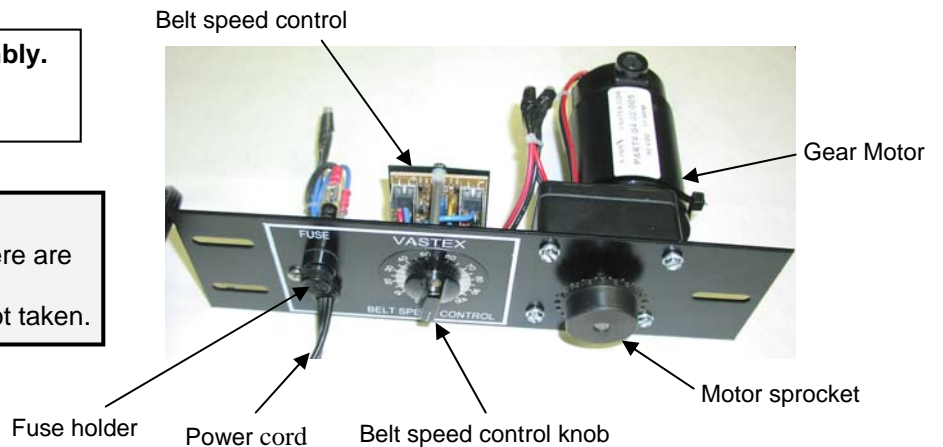

Troubleshooting

IMPORTANT Turn off and lock out power at the main disconnect before entering any part this equipment . Do Not operate with any covers or guards removed.

Belt Speed Controller adjustment

Setting the low speed pot adjustment: (small screw driver with plastic handle is needed)

Turn the speed pots clockwise to increase the speed and counterclockwise to decrease. The low speed pot should be set so the belt (or sprocket) moves very slow at the lowest setting on the controller, just before the controller is clicked in the off position. The high setting is set so 90 VDC is the maximum voltage to the motor, a volt meter is needed for the high speed adjustment. The control assembly should be placed on a bench so the speed pots are up and accessible.

Caution: Do not touch the open wires around the controller and the fuse holder.

Pot near the white wires LOW SPEED.

Pot near the blue wires HIGH SPEED.



This view of the control assembly “upside down” is to show you the speed pot adjustments on the bottom side of the controller.

No Heat

Please set controller to at least “5” for diagnostics.

	Possible Cause	Solution
Red Pilot Light out	Loose connections Customer power failed or outlet failed Controller bad	Check connections Check power at main disconnect Replacement controller
Red Light on	Loose connections Bad controller Bad Heater	Check connections Replace controller Replace Heater
Heat not cycling on and off	Bad controller	Replace controller

Belt Stopped

	Possible Cause	Solution
Motor still turning	Broken chain drive Loose sprocket set screws	Replace chain & worn sprockets Tighten sprocket set screws
Motor & drive pulley are turning	Obstruction in belt path Belt loose	Clear jam Tighten belt

IMPORTANT READ BEFORE OPERATING DRYER

Restricting the dryers exhaust will effect the operation of the dryer. Excessive heat buildup within the chamber may damage the exhaust blower. Proper venting is important.

EC-II SERIES SINGLE & DOUBLE CHAMBER DRYERS

The Exhaust Hood is an option for all Vastex Dryers

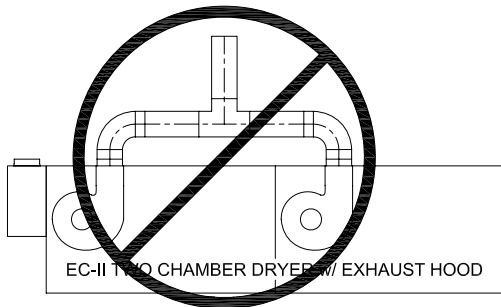

**Exhaust blower damage will result
WRONG**

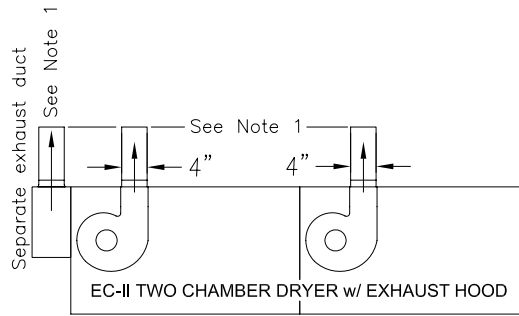

**SEPERATE EXHAUST DUCTS
ACCEPTABLE**

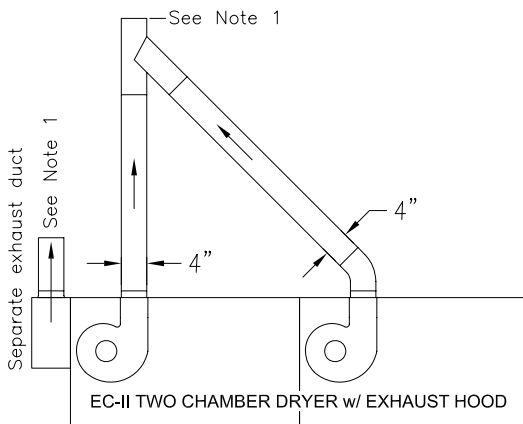

**45° TEE WYE DUCTING
ACCEPTABLE**

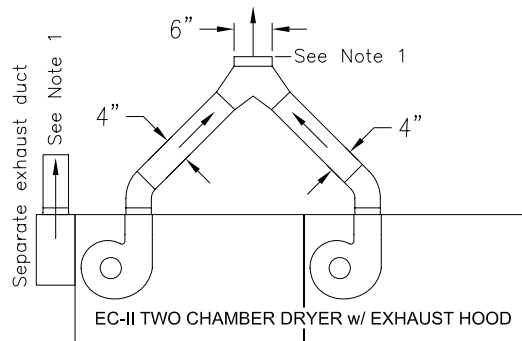

**WYE JOINT DUCTING
ACCEPTABLE**

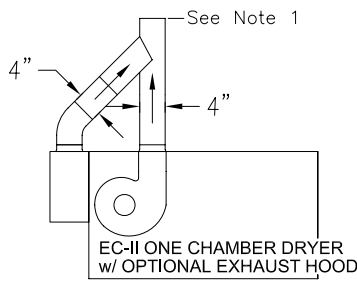

**45° TEE WYE DUCTING
ACCEPTABLE**

EC-I & DB SERIES DRYERS

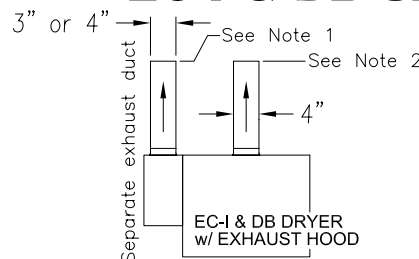

**SEPERATE EXHAUST DUCT
ACCEPTABLE**

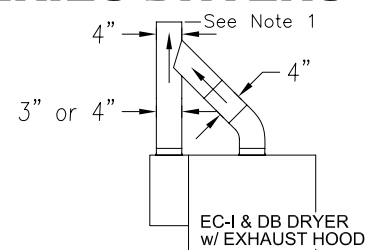

**45° TEE WYE DUCTING
PREFERRED**

Note:

1.) CFM reduction from this point to end of ducting should not exceed 10%. Add auxiliary blower when necessary.

2.) Requires exhaust blower when venting dryer outside.



Doc. # 01-01-014

Installation: Conveyor Belt Covers DB Series and EC-I Series Dryers

Vastex International, Inc.
1032 N. Irving St.
Allentown, Pa. 18109 USA
Phone# 610 434-6004
Fax# 610 434-6607
Web Site www.vastex.com
E-Mail info@vastex.com

Package Contents:

- (3) Belt Covers (actual covers may differ from pictures)
- (1) Chain Guard
- (8) Sheet Metal Screws

Tools Required: 1/4" Nut Driver, or 1/4" socket and ratchet

Conveyor Front

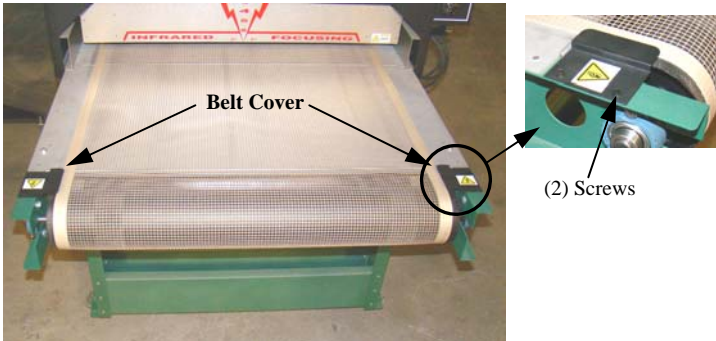

Conveyor Rear

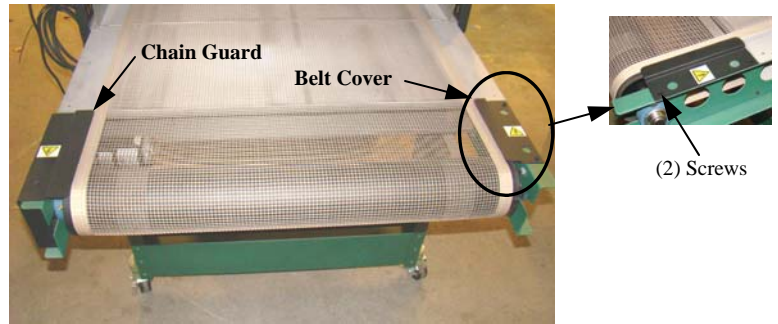

Doc. # 01-01-014

Installation: Conveyor Belt Covers DB Series and EC-I Series Dryers

Vastex International, Inc.
1032 N. Irving St.
Allentown, Pa. 18109 USA
Phone# 610 434-6004
Fax# 610 434-6607
Web Site www.vastex.com
E-Mail info@vastex.com

Package Contents:

- (3) Belt Covers (actual covers may differ from pictures)
- (1) Chain Guard
- (8) Sheet Metal Screws

Tools Required: 1/4" Nut Driver, or 1/4" socket and ratchet

Conveyor Front

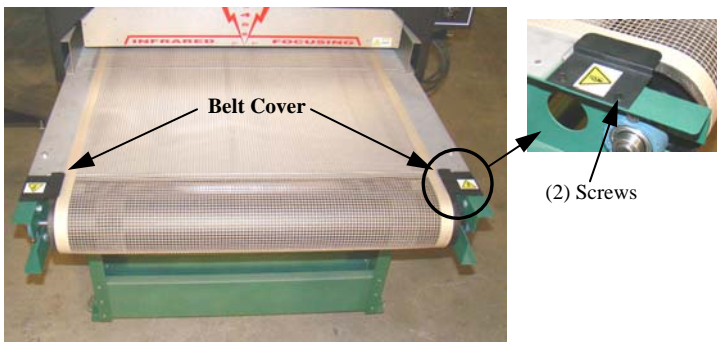

Conveyor Rear



Vastex Warranty

Doc#01-00-005B Revised 04/10/12

(1.) Vastex, hereinafter referred to as "seller" warrants only to its original "purchaser", who holds a copy of the original invoice and is the original end user of the equipment in question, its new equipment against defects in materials or workmanship on a pro-rated basis. Warranty period begins from date of shipment to the buyer and will only apply to customers paid in full. Warranty periods are as follows: one (1) year for E-1000, three (3) years for all other complete machines (including F-Flash), fifteen (15) years for infrared heaters (excluding F-Flash) installed by Vastex in a new dryer, three (3) years for replacement infrared heaters, and one (1) year for replacement parts. Rubber blankets, light bulbs and glass on exposure units are particularly subject to wear while in use. Wear is not covered by this warranty but as stated above only manufacturers defects are covered. All sales made through Vastex dealers must be certified by that dealer before a warranty replacement is issued.

(2.) This warranty is expressly contingent upon the buyer delivering to seller, at the address below, with all transportation charges prepaid, the part or parts claimed to be defective within the above mentioned warranty periods stated in paragraph one. The defective part or parts will be repaired or replaced at the discretion of Vastex International, Inc. If the equipment in question is less than one (1) year old, it will be shipped to the customer at no charge, with an RGA issued by Vastex for the defective part. The defective part must be shipped back to Vastex freight prepaid within 30 days or the account will be billed. If the equipment is more than a year old, the part will be shipped after we receive the defective part. If it's necessary to expedite the movement of parts and to minimize down time to the buyer, the replacement part shall be supplied on a C.O.D. basis. If testing and analysis of said part by the seller or its supplier discloses that said part is defective, the cost of said part will be refunded to the buyer on a prorated basis.

(3.) Except as otherwise provided herein, the equipment is being sold "as-is". Final determination of the suitability of the equipment for the use contemplated by the buyer, is the sole responsibility of buyer, and seller shall have no responsibility in connection with the suitability.

(4.) All warranties implied by law, including the implied warranties of merchantability and fitness are hereby limited to workmanship and defective parts to a warranty period stated in paragraph one. The express warranty and remedies contained herein and such implied limited warranties are made solely to the sole warranties and remedies and are in lieu of all other warranties, guarantees, agreements, and other liabilities, whether express or implied, and all other remedies for breach of warranty or any other liability of seller, in no event shall seller be liable for consequential damages.

No person, agent, distributor, or service representative is authorized to change, modify or extend the terms hereof in any manner whatsoever.

These terms and conditions are an essential part of the transaction between the parties and constitute the entire agreement between them with respect to the same.

Some states do not allow limitation on how long an implied warranty lasts of the exclusion or limitation of incidental, or consequential damages, so the above limitation may not apply to you.

This warranty gives you specific legal rights, and you may also have other rights which vary from state to state.

Infrared heaters are the only replacement parts covered for a period of (3) years from date of shipment and contingent to receipt of payment in full.

Electrical components cannot be returned once installed unless proven defective.

Please refer to doc. 01-00-015 for specific terms and conditions of sale and the limited warranty.

Please refer to doc. 01-00-017 for V-2000HD printer warranty.

Updates: V1000 to 3 year warranty 01/09/12, Heater warranty to 15 years 01/02/2012.

TERMS AND CONDITIONS OF SALE AND LIMITED WARRANTY Doc.#01-00-015

1. Buyer's order will constitute an offer in accordance with the terms hereof and such offer, upon acknowledgment of Seller, will constitute the agreement between Buyer and Seller. Buyer's order after such acknowledgment by Seller will not be subject to cancellation, change or reduction in amount, or suspension by Buyer of deliveries, unless prior to such action Buyer has obtained Seller's written consent. Notwithstanding anything to the contrary in Buyer's Purchase Order or other communications, the parties agree to be bound by these Terms and Conditions. Acceptance of the product by the Buyer shall be deemed to constitute unconditional acceptance of these Terms and Conditions.
2. Any of these terms, conditions and provisions of Buyer's order which are inconsistent with Seller's acknowledgment and these Terms and Conditions of Sale shall not be binding on the Seller and shall be considered not applicable to any sale so made. No waiver, alteration or modification of any of the provisions on either side of the document shall be binding upon Seller unless agreed to in writing by Seller.
3. (a) All prices are F.O.B. Seller's Plant and method of delivery and routing shall be at Seller's discretion, unless specifically otherwise stated herein. Notwithstanding any agreement to pay freight, delivery of products purchased hereunder to a common carrier or licensed trucker shall constitute delivery to Buyer and be determinative of the date and time of shipment and all risk of loss or damage in transit shall be borne by Buyer. If the Buyer fails to accept the goods from the common carrier or licensed trucker, the Seller shall be entitled to claim payment from the Buyer. Seller shall arrange for storage, the risk and the cost, including insurance costs, to be borne by the Buyer (and Buyer agrees to pay such amounts upon demand) except if the failure to accept delivery is due to any of the exceptions noted in Paragraph 4.
(b) Terms of payment shall be as stated on invoice.
4. It is understood that deliveries will be made in accordance with Seller's regular production schedule. Every reasonable effort will be made to meet the Buyer's required delivery dates but Seller will not be liable for damages or be deemed to be in default by reason of any failure to deliver or delay in delivery due to any preference, priority, allocation or allotment order issued by the Government, whether Federal, State or local, or causes beyond its control including but not limited to, Acts of God or a public enemy, acts of Government, fires, floods, epidemics, quarantine restrictions, strikes, lockouts, freight embargoes, severe weather, unavailability of materials or shipping space, delays of carriers or suppliers or delays of any subcontractors. Should delay in delivery be caused by any of the circumstances mentioned in this paragraph, such extension of the delivery period shall be granted as is reasonable under the circumstances of the case. Should delay be caused by an event not specifically mentioned in this paragraph, damages will be limited to cancellation of the purchase order without penalty, and refund of any monies deposited or prepaid on the purchase order with no liability for any consequential or incidental damages.
5. Seller reserves the right to increase the prices prior to Seller's acceptance of order and/or after expiration of any price quoted by Seller.
6. Unless otherwise stated in writing, Seller's prices do not include sales, excise, value-added or other taxes. Consequently, in addition to the price specified herein, the amount of any present or future sales, use, excise, value-added or other tax applicable to the manufacture, sale, purchase or use of the products hereunder shall be paid by Buyer, or in lieu thereof, Buyer shall provide Seller with a valid tax exemption certificate acceptable to the taxing authorities.
7. Seller reserves the right, at any time, to revoke any credit extended to Buyer because of Buyer's failure to pay for any products when due or for any other reason deemed good and sufficient by Seller and in such event, all subsequent shipments shall be paid for prior to at delivery at Seller's option.
8. (a) SELLER'S LIABILITY SHALL BE LIMITED TO SELLER'S STATED SELLING PRICE PER UNIT OF ANY DEFECTIVE GOODS AND SHALL IN NO EVENT INCLUDE BUYER'S MANUFACTURING COSTS, LOST PROFITS, GOODWILL, OR ANY OTHER SPECIAL, INDIRECT, INCIDENTAL OR CONSEQUENTIAL DAMAGES, ARISING OUT OF THE AGREEMENT, THIS CONTRACT, THE SALE OF THE PRODUCTS TO THE BUYER OR THE USE OR THE PERFORMANCE OF THE PRODUCTS. Seller may at its discretion repair, replace or give the Buyer credit (pro-rated) for such defective products.
(b) Notwithstanding anything herein to the contrary, Seller shall have no liability for alleged defects with the products which are not specified in written notice from the Buyer to the Seller within thirty-six (36) months from the date of shipment of machines. Seller shall pass to Buyer any warranty received by Seller from the manufacturer of Limited Life Components, which in most cases is 12 to 18 months.
(c) Seller shall have no liability under this Limited Warranty unless Buyer has paid in full for the products. Further, this Limited Warranty is expressly contingent on Buyer's delivery to Seller, all costs prepaid, the defective part(s) within thirty-six (36) months of shipment to Buyer, together with a written statement specifying the alleged defect(s). Any replacement part(s) shall be shipped to Buyer on a C.O.D. basis.
(d) SELLER SPECIFICALLY EXCLUDES ALL WARRANTIES, EXPRESSED, IMPLIED OR OTHERWISE, EXCEPT AS STATED EXPLICITLY IN THESE TERMS AND CONDITIONS OF SALE. SELLER DISCLAIMS THE WARRANTY OF MERCHANTABILITY AND FITNESS FOR A PARTICULAR PURPOSE.
9. The remedies herein reserved by Seller shall be cumulative and in addition to any other legal remedies. No waiver of a breach of any portion of this contract shall constitute a waiver of continuing or future breach of such provision or of any other provisions hereof.
10. These Terms and Conditions constitute the entire agreement of the parties. No amendments, changes, revisions or discharges hereof in whole or in part shall have any force or effect unless set forth in writing and signed by the parties hereto. This contract shall not be assignable by Buyer voluntarily by operation of law or otherwise without Seller's written consent.
11. This contract shall be governed and shall be construed according to the domestic laws of the Commonwealth of Pennsylvania.
12. Anything herein to the contrary notwithstanding, any action for alleged breach by Seller of the contract between the parties, including but not limited to any action for breach of the warranties herein set forth, shall be barred unless commenced by Buyer within one (1) year from the date such cause of action accrued.
13. This agreement shall inure to the benefit of and be binding upon the parties hereto, their respective successors and permitted assigns.
14. All notices required by this contract to be given by either party shall be sent in writing or by facsimile and shall be addressed to the last known address of such other party. Notices shall be deemed to have been received on the fifth business day following deposit in the mail.

VASTEX WARRANTY IMPLEMENTATION SHEET

Please read this document in order to fully understand the warranty.

Doc.# 01-00-006

Your new Vastex equipment is protected against *manufacturers' defects by our warranty, completely explained in doc# 01-00-017 for the V2000-HD series manual printer and in doc# 01-00-005 for all other Vastex manufactured equipment. Please refer to these documents for the **warranty term and specific concerns about the warranty. The following are some important facts and requirements for the proper implementation of the warranty.

1.0 Everything is covered!

2.0 **Warranty Term is defined as: Ship date from VASTEX to the date the item in question is returned to VASTEX for inspection and repair.

3.0 *Manufacturers defects are defined as: Parts determined to be defective in workmanship which will lead up to a premature failure. The determination will be made only by the manufacturer of the item in question.

4.0 To take advantage of the warranty the following steps must be taken:

4.1 The equipment must be paid for in full.

4.2 The item in question must be shipped to VASTEX for evaluation with all shipping costs incurred by the buyer.

4.3 If the item is deemed as a manufacturer's defect it will be repaired or replaced within 2 business days from the time received. The shipping cost back to the customer located in the continental United States will be paid by VASTEX if a warranty item.

4.4 **If the item in question must be replaced immediately and is more than a year old, it will have to be purchased at list price and will be shipped COD. A pro-rated credit will be given promptly if the returned item is a valid manufacturer's defect.**

4.5 If the equipment was shipped less than a year before the date of the service call and a technician confirms the part needed for repair, the replacement will be shipped before the replacement is shipped back. An RGA will be issued and must accompany the old part to VASTEX within 30 days or the account will be billed.

5.0 Important facts about the condition of shipped equipment:

5.1 Dryers are partially assembled with the belts tracked and the machine run at full temperature for a min. of 1 ½ hours.

5.2 Printers are partially assembled, inspected, and adjusted for all heads down prior to partial disassembly and packing.

5.3 Exposing units are fully assembled and tested with the maximum screen size for vacuum integrity, timer operation and light output.

6.0 This document is in addition to the standard warranty and only helps the customer understand how to take advantage of the warranty. In no way does this document override the standard warranty or the terms and conditions of sale and the limited warranty doc# 01-00-015.

Please see doc# 01-00-015 for specific terms and conditions of sale and the limited warranty