

# VASTEX

## SCREEN PRINTING EQUIPMENT

### INTRODUCTION TO SCREEN PRINTING

Welcome to our introduction to screen printing. We hope to answer at least some of your questions, but if you need more information, call 1-800-482-7839 or visit our website at [www.VASTEX.com](http://www.VASTEX.com).

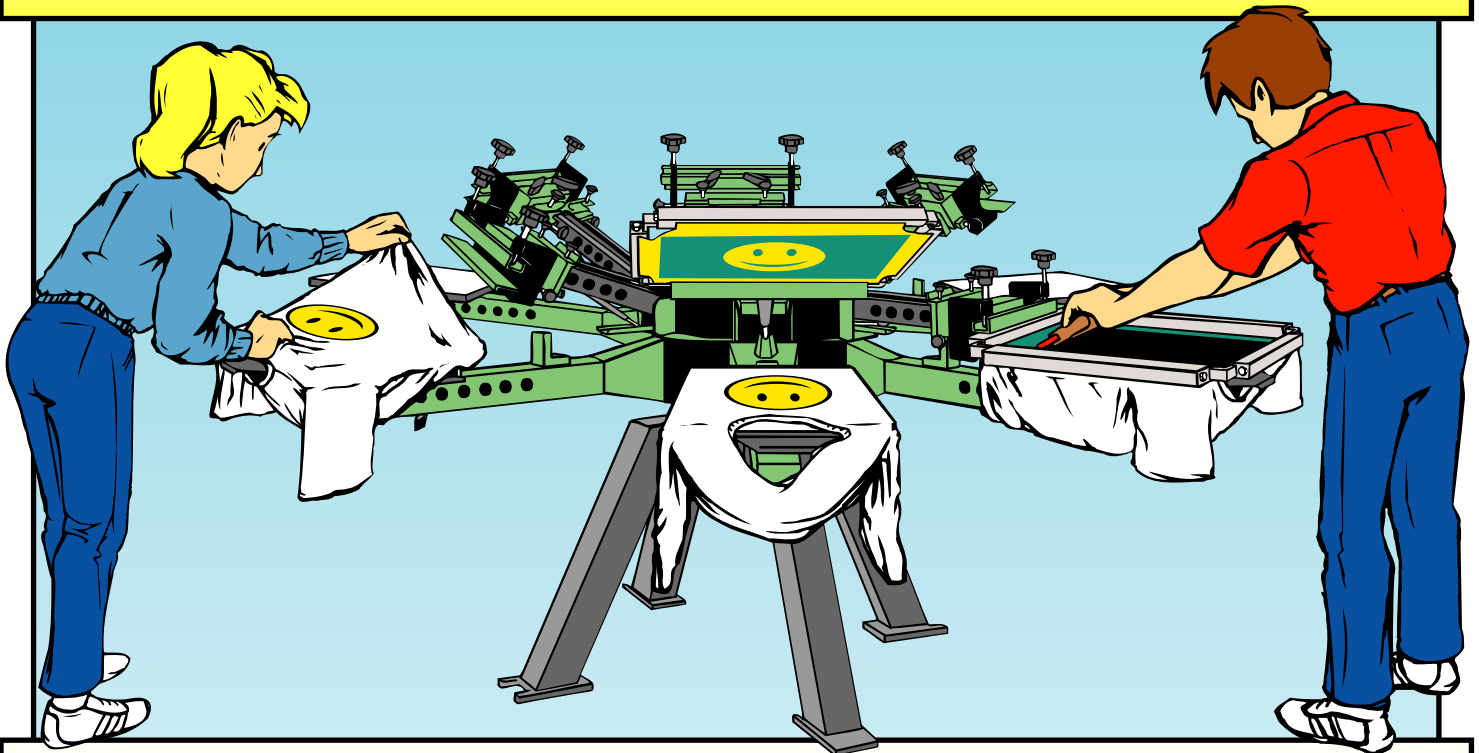

### Screens - Exposure - Production - Cleaning



Written by: Douglas Grigar - Illustrated by: Mike Kelly and Douglas Grigar  
Copyright 2003-2005 Vastex Inc.

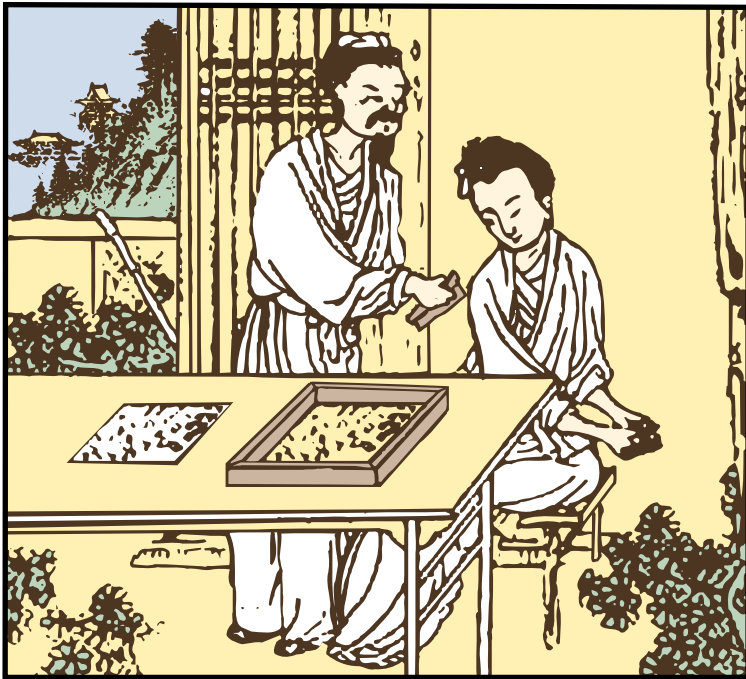

## Screen printing? Whatever happened to silk?

The evolution of screen printing began thousands of years ago when printers around the world began using cut stencils made from natural materials and paper for printing. The Japanese and the Chinese developed wooden frames to support the stencil which was glued onto a woven fabric mesh. This mesh, originally made from human hair, eventually was woven from silk, hence the name "silk screen printing". The resulting mass production of ink-decoration on paper, clothing, books, and many other surfaces became an important part of Asian culture.

In the late 1800s, artists and printers in France and Germany advanced the process, and it was given an English patent in 1907. In the late 1930s, artists coined the term "serigraphy" (derived from the Latin word *seri* [silk] and the Greek word *graphein* [to write]) to describe this medium distinguishing it from commercial screen printing. Today, screen printing uses manmade threads of steel, nylon, and polyester - no silk at all.

### 1. OK professor, how does it work?

Screen printing starts with just that: a screen - mesh fabric stretched tightly across a rigid frame. **What is mesh?** Mesh is any fabric manufactured to have thousands of wide spaces between the threads. This spacing allows ink to squeeze through.

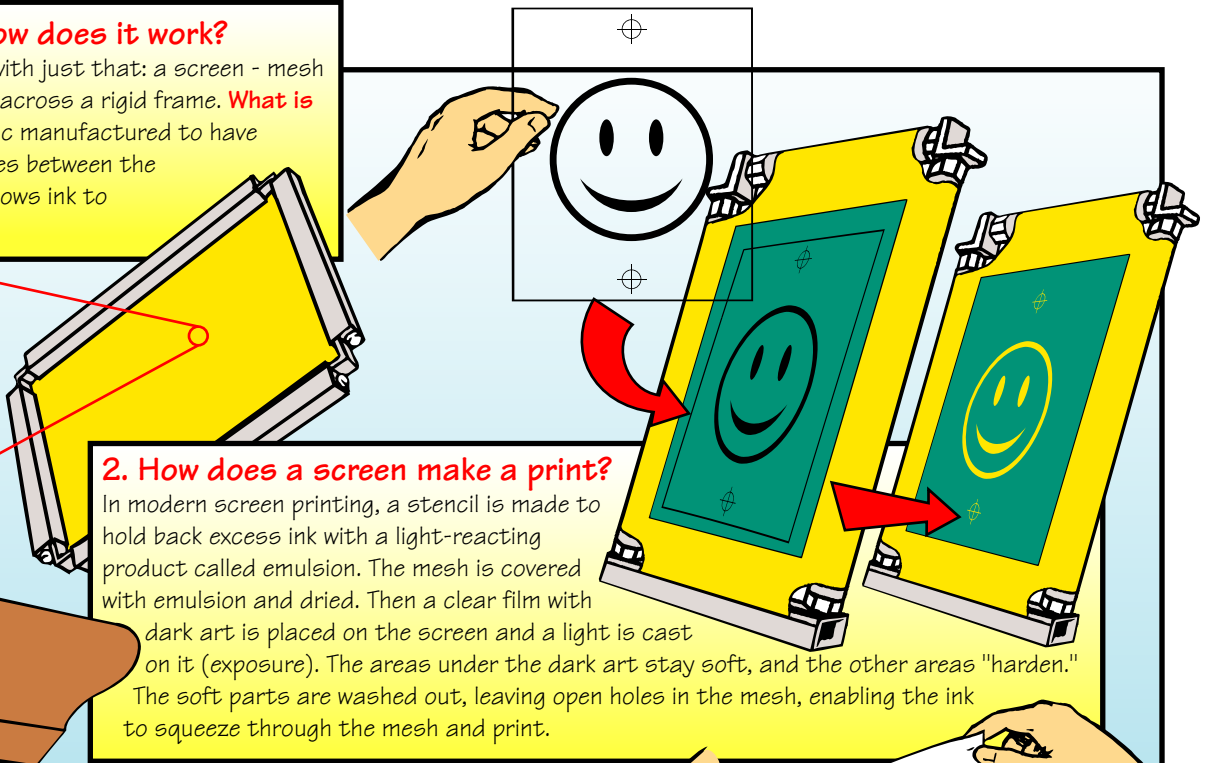
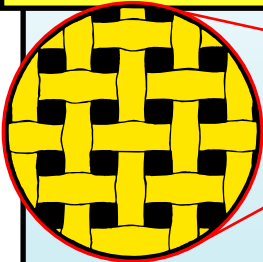

### 2. How does a screen make a print?

In modern screen printing, a stencil is made to hold back excess ink with a light-reacting product called emulsion. The mesh is covered with emulsion and dried. Then a clear film with dark art is placed on the screen and a light is cast on it (exposure). The areas under the dark art stay soft, and the other areas "harden." The soft parts are washed out, leaving open holes in the mesh, enabling the ink to squeeze through the mesh and print.

### 3. How does the ink squeeze through the mesh past the stencil?

Enter the squeegee a flexible plastic blade in a handle. The squeegee puts pressure on the ink and sends it past the fabric threads. It leaves a thin layer of ink on the product and "shears off" the excess. That's all there is to it! To print multiple colors, a separate screen is needed for each color. For multi-colored products, such as T-shirts, multi-armed printers are used to hold the colors to assure an exact line-up.

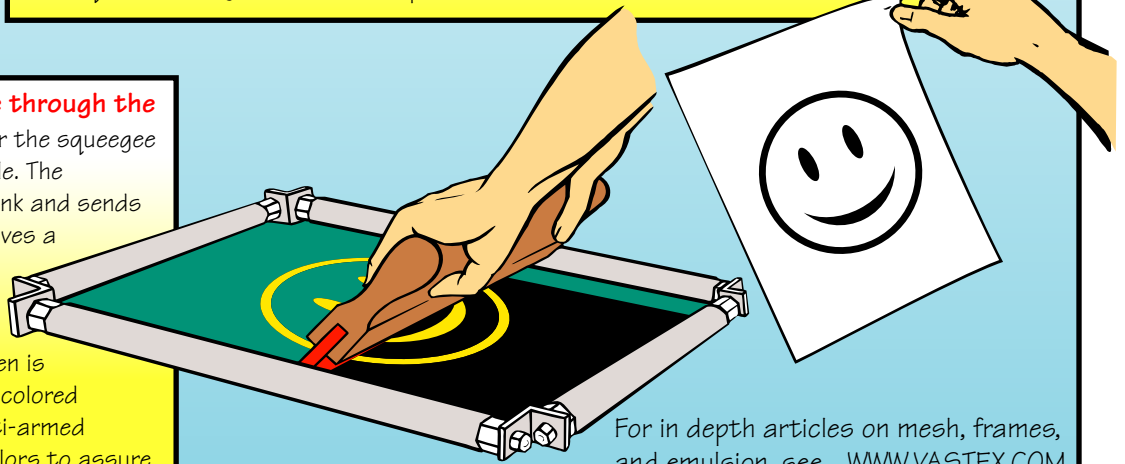

For in depth articles on mesh, frames, and emulsion, see... [WWW.VASTEX.COM](http://WWW.VASTEX.COM)

**1. Since we're talking about printing T-shirts, let us introduce you to our T-shirt printing equipment.**

First, our V-2000 HD multi-color T-shirt press. Simply put, this monster-like machine will hold multiple garments and print more than one color, while perfectly holding colors "in line." (Remember: Each color needs its own screen!) The V-2000 HD is available as a one-color "table top" model or with capabilities for up to a 10-shirt, 10-color-arm press. All presses are expandable (to grow as your shop grows), and will hold our high-speed professional numbering systems, cap printers, and sleeve-printing boards.

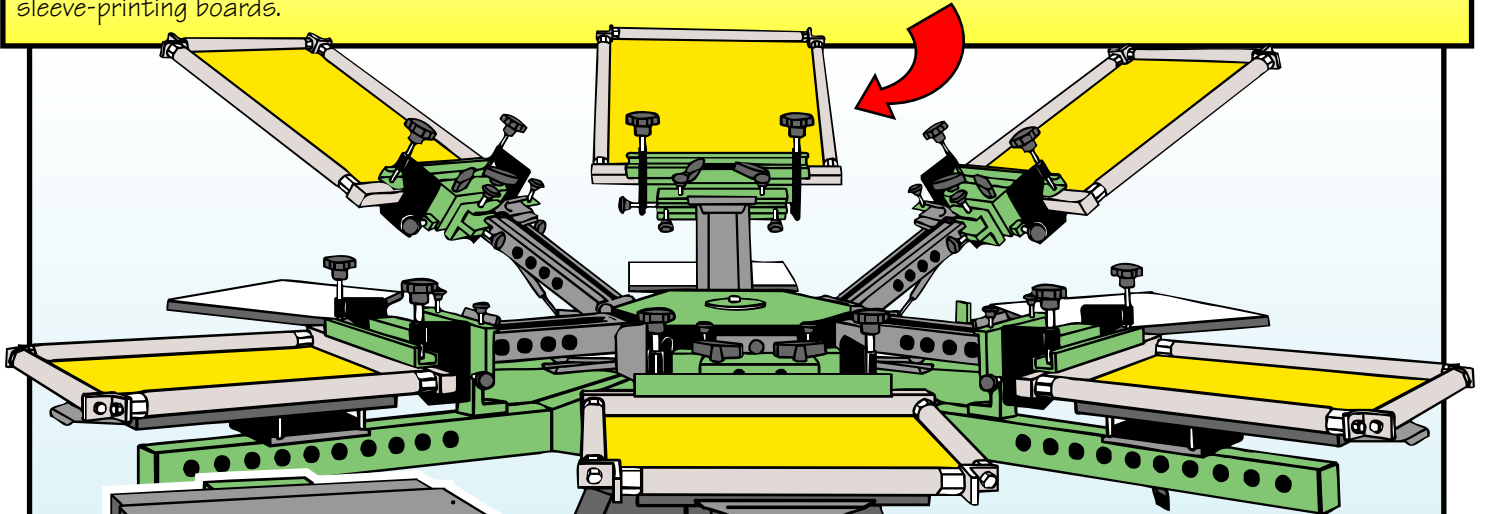

**2. Printing more than one color or dark shirts?**

Second is our E-Flash for "flashing" (drying) the colors while printing on the press. Used for multi-color jobs where you don't want to smear ink, or dark colors where you need to print ink under other colors (an underlay).

**3. Drying the ink.**

Third, is our expandable Econo Red conveyor dryer. In this machine, the high-output infrared and digital electronic heating controls assure that settings are consistent. Our infrared panels use just the right wavelength to provide an efficient cure. (Plastisol must cure with the entire layer of ink at 310°-320°.)

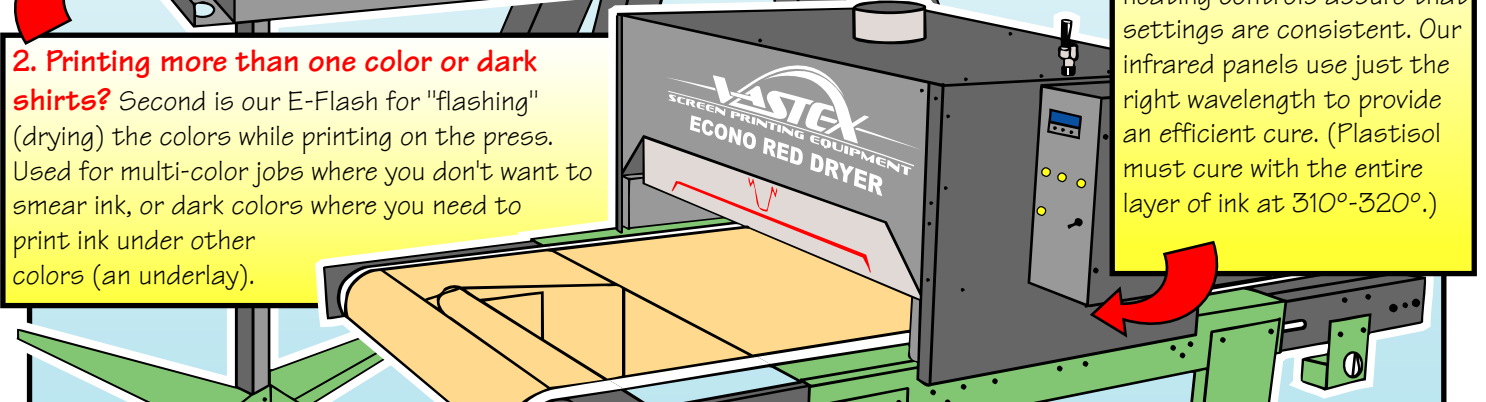

**4. Exposing the emulsion.**

Fourth, our automatic timed Exposit ultraviolet screen exposing unit. This machine uses a professional deep-draw rubber blanket and heavy duty vacuum, and has the VRS stops installed (see page 5). A dual hinged lid can also be used for side or solar exposure.

**5. Fast press "set up" time.**

Fifth, our expanded VRS (Vastex Registration System) is available with an easy to use steel platen jig that will reduce screen mistakes and reduce screen "set up" by over HALF the normal time!

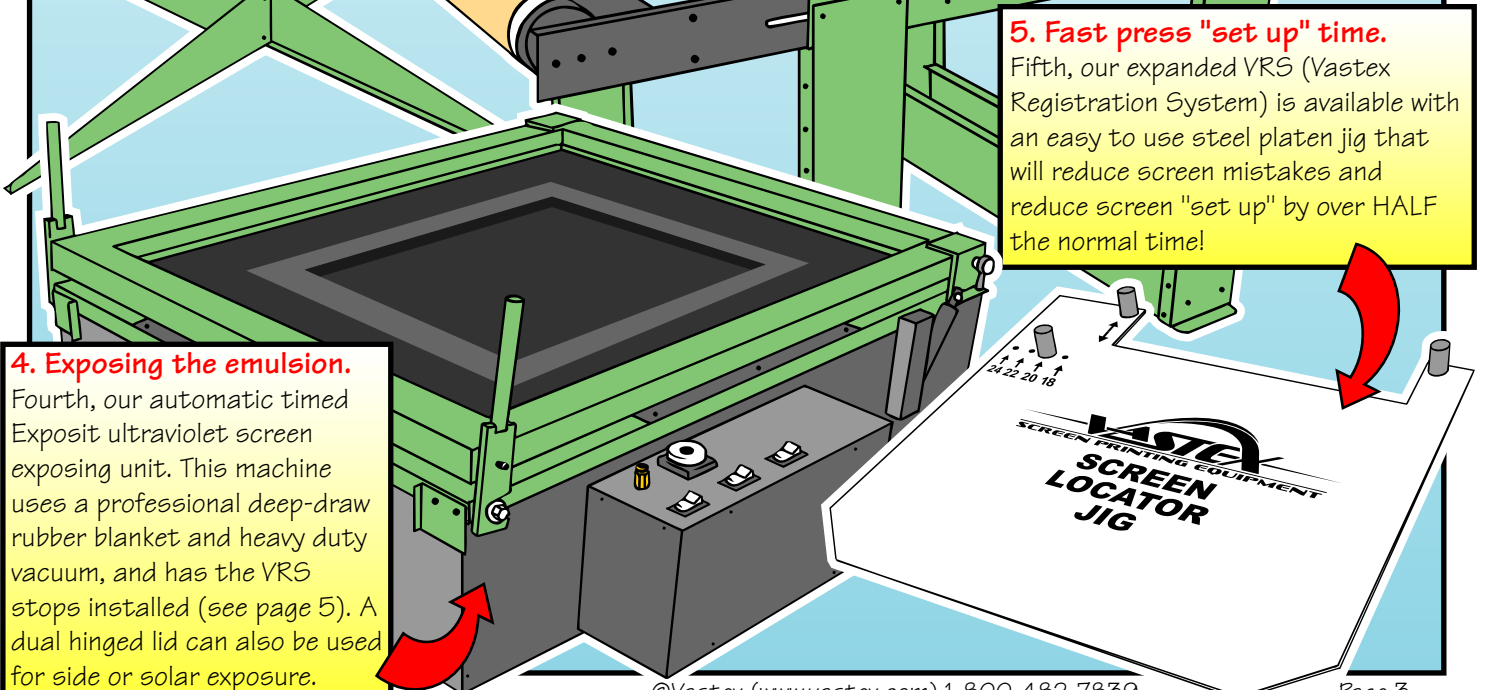



**So, all that neat stuff shows up on the truck. Now what?** Even though this is easier than programming a DVD player. **READ THE DIRECTIONS!** When unpacking, be careful not to break anything with a crowbar or a hammer. Have your electric service, sinks or booths for water washout, and drying cabinets ready. Call us if you are unsure about what you need (1-800-482-7839). We can provide on-site training, host regular classes and have detailed supply information available.

**1. How it all works.** Start at the point when the press, exposure unit, flash, and dryer are in place and assembled. Gather the screen frames together and begin screen preparation. Note: A higher quality screen (such as a retensionable frame) produces the best results.\*

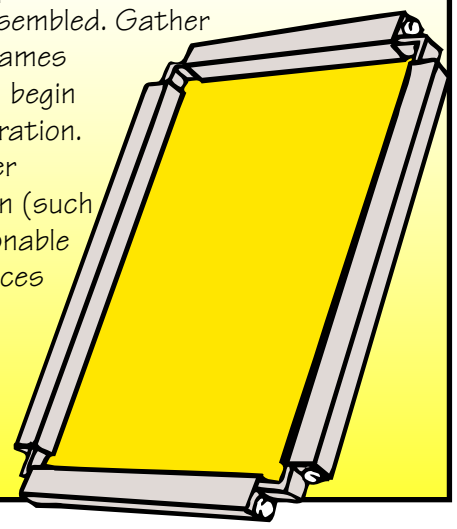

\*For an in-depth article on frames, suggested supplies, and other technical information, see [www.VASTEX.com](http://www.VASTEX.com).

**2. Clean (degrease) the screens.** Even though they're new, the screens will still need a thorough cleaning. Lather up using a degreaser and a soft, clean brush. Rinse with clean water.

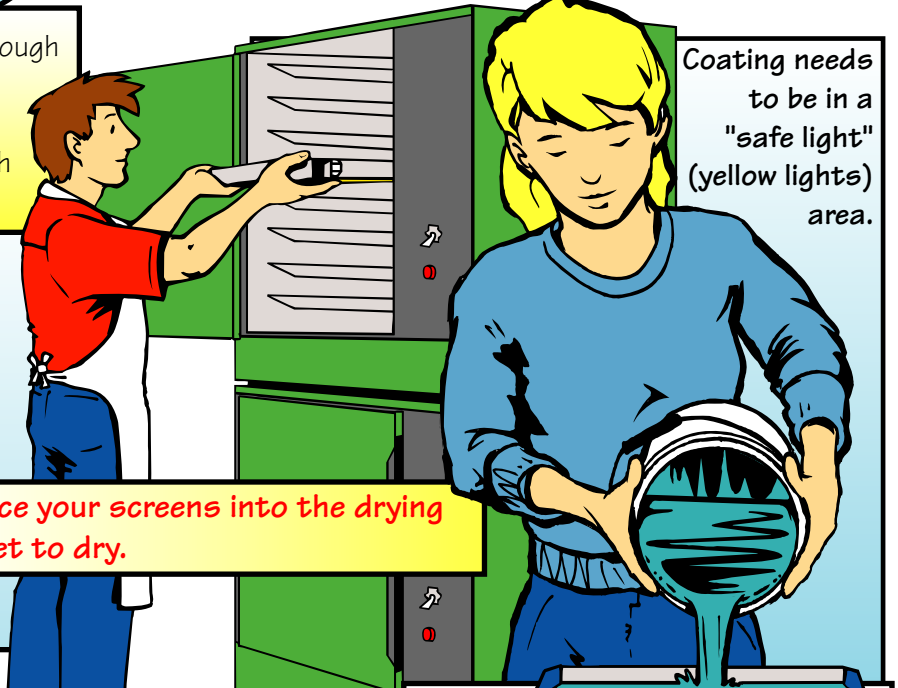
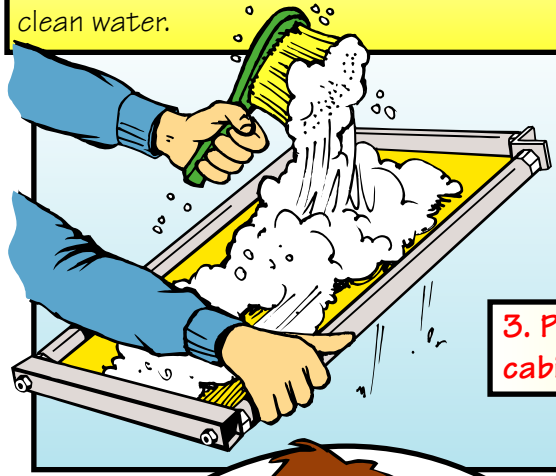

Coating needs to be in a "safe light" (yellow lights) area.

**3. Place your screens into the drying cabinet to dry.**

**4. Fill a coating "trough" with the liquid emulsion.** You are now ready to put the emulsion on the screens. This step is called "coating."



**5. Coat the screens with emulsion.** Tip the coating trough, when the emulsion flows to the mesh, apply pressure, and draw the coater slowly up the screen. Coat both sides of the screen (shirt then squeegee side).

**6. Back into the drying cabinet.** The screen goes into the cabinet shirt side down. The drying cabinet will keep dirt and dust from accumulating on the drying screen.

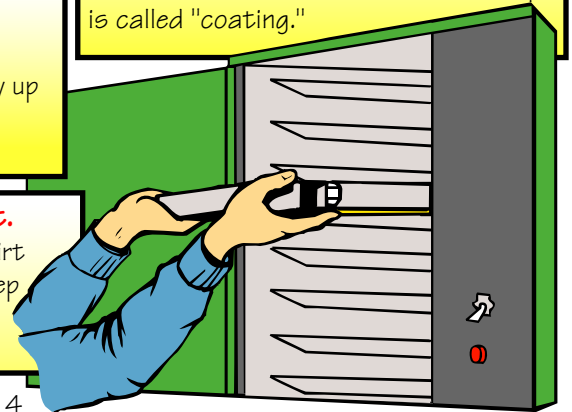

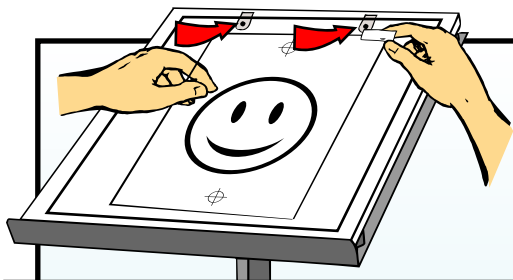

**1. Tape art to the film carrier sheets.**  
Use the VRS pin board to make sure the art is lined up. The VRS system prevents you from having to repeat the same alignment procedure in each step. The key is that the two pins work only one way no mistakes!

**2. Exposit - where it all comes together...** The one way pins, carrier sheets, and VRS-stops all work together here. Place the art on the pins; line the screen to the stops; expose; then go to the wash booth.

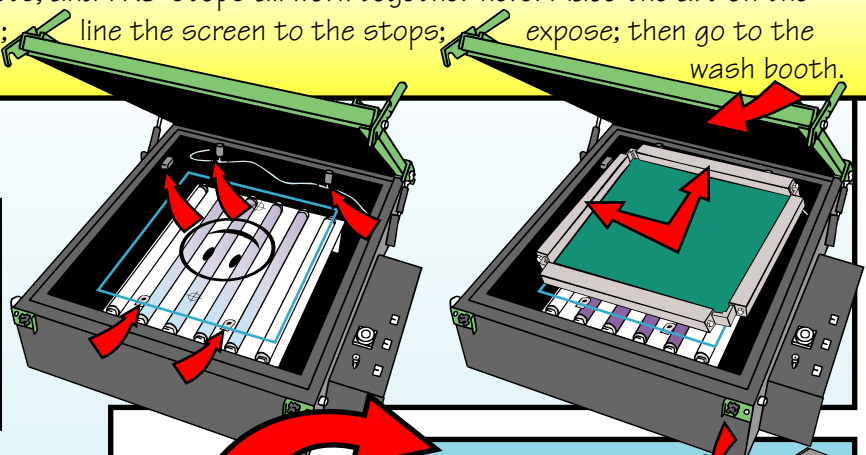

**3. After exposure, develop or "wash out" in the spray booth.** Using a fan spray, keep the spray nozzle about one yard from the screen face. The soft emulsion left by the dark art areas will spray out. The dark (opaque) portion of the positive will prevent the emulsion from linking.

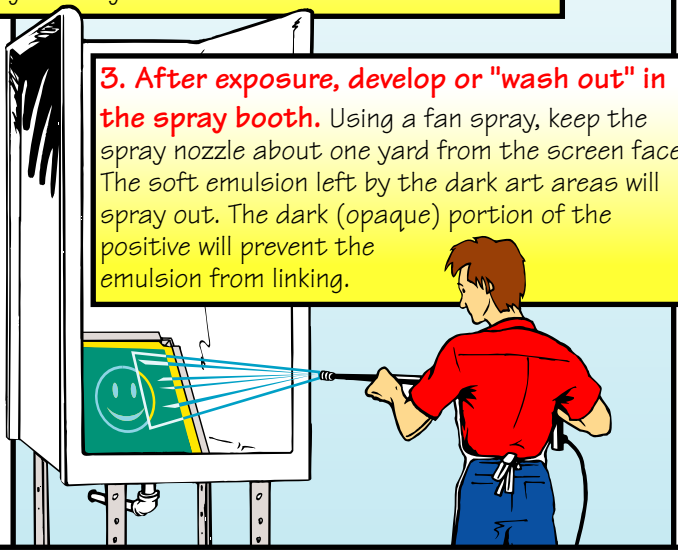

**6. Adjust the angle.** Each head on the V-2000 has vertical off contact, pitch, and "on-the-fly" pitch control.

**7. Lock the VRS jig on a platen.** You will see that the three stops match the stops on the Exposit. Position the pallet so the screen is well into the rear clamp.

See our flash VRS on [VASTEX.com](http://VASTEX.com).

**4. Use the special vacuum head on a shop vac to remove excess water and any loose emulsion.** Dry the screens in the drying cabinet or in the sun. The image is now in the screen, and contamination will no longer be a problem.

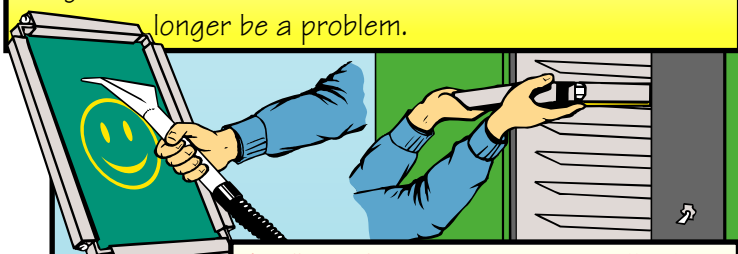

**8. Place the screen onto the jig.** Level the print head, push the screen against the stops, and tighten the clamp knobs.

**5. When the screens are totally dry.** Tape the inside edges and corners and check for pinholes. After all screens are taped and any pinholes blocked (on the shirt side, NOT the ink side!), it's time to print.

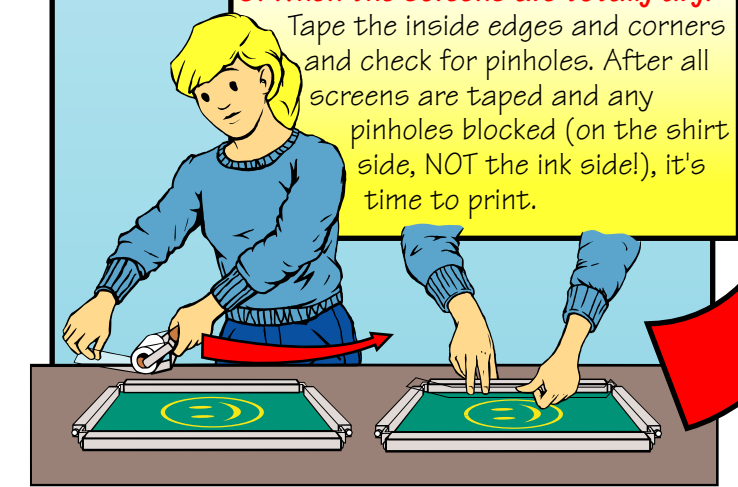

**9. Fine adjustments.** Our direct linear, zero backlash, micro-registration will make moving the image into perfect registration a snap.

the VRS cuts "set-up" time by HALF or more!

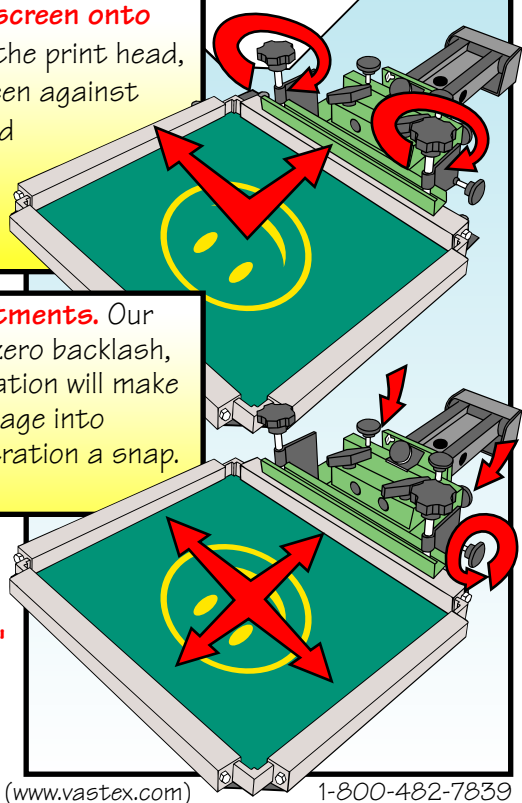

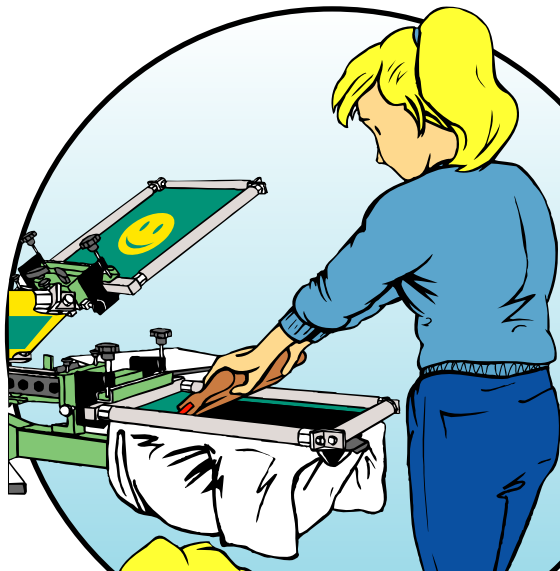

**1. Print your colors.** Push the squeegee across the screen. This step enables you to push the ink into and past the mesh and shear it onto the shirt. Lift the screen and move to the next color in line.

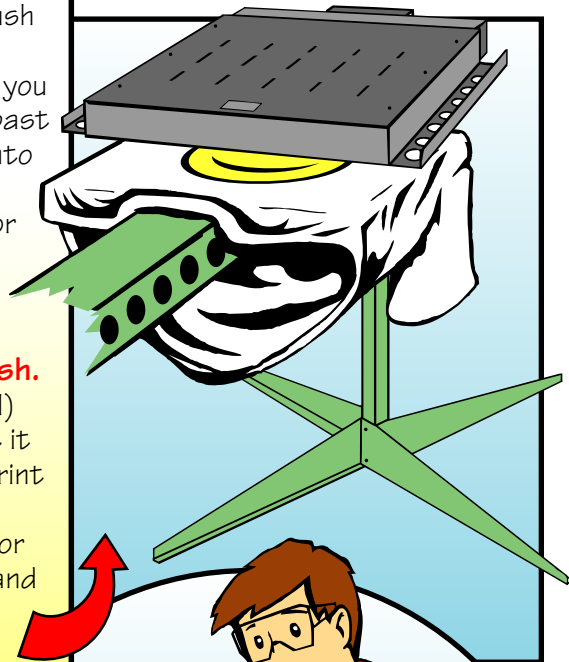

**2. Flash with the E-Flash.** The flash will tack dry (gel) the top of the ink so that it will not smear when you print the next color. On dark shirts, a printed undercolor will keep the print bright and prevent shirt color from showing.



**4. Ink spots on the shirts?**

Use the spot cleaning gun to blow out spots. Be careful, and wear protective gear.

**READ YOUR SAFETY INFO!**

Scorches can also be removed at this time with other chemicals.



**3. Place the printed shirt on the dryer belt.**

The conveyor dryer will pass the shirt under the infrared heat for a consistent amount of time. Plastisol ink will cure (dry) when the total thickness reaches 310°- 320°. The dryer controls the speed (time) and heat.

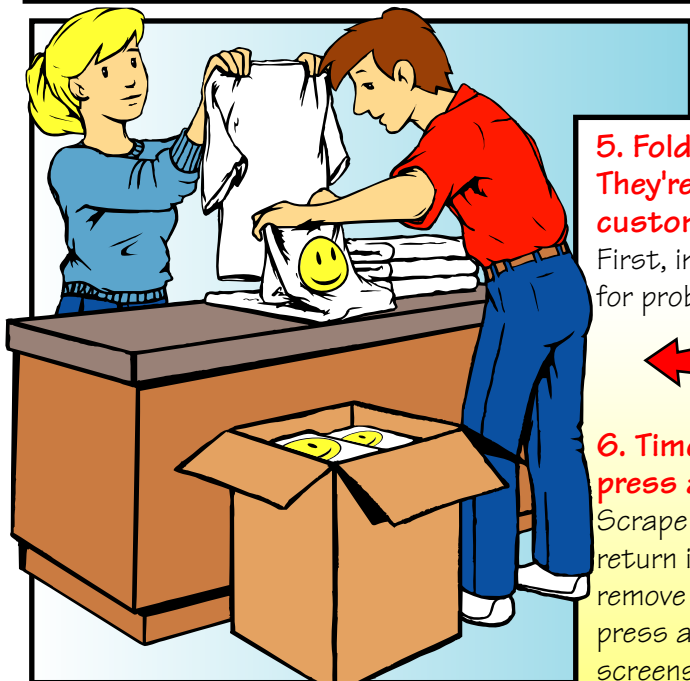

**5. Fold and box up the shirts. They're ready for your customer.**

First, inspect both sides carefully for problems and print quality.

**6. Time to "break down" the press and start cleaning.**

Scrape off the unused ink and return it to the buckets. Carefully remove the screens from the press and take all tools and screens to the wash area.

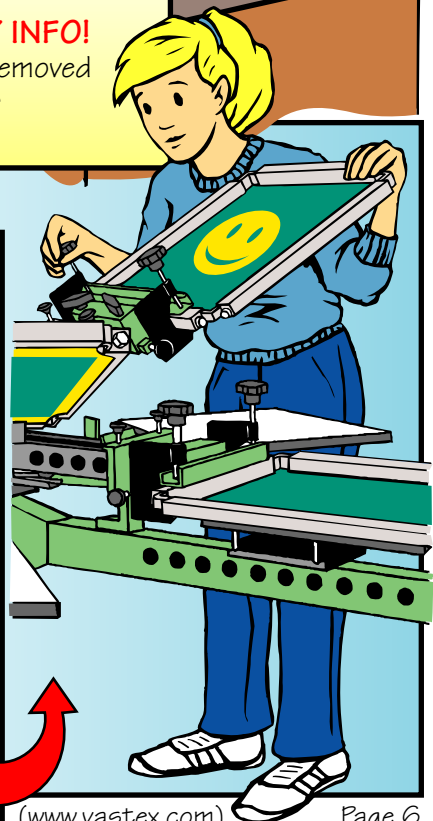



**1. Pull off the tape.** After scraping off as much ink as you can with a scoop or card, pull off the tape. The tape prevents the ink from leaking, but removing it can be very messy!

**2. Wash the ink off the screen in the wash sink.** Use an ink degradant, spray, then scrub and rinse off all ink in the wash sink. (Another option would be to rent chemicals and a recirculator from an outside source.)

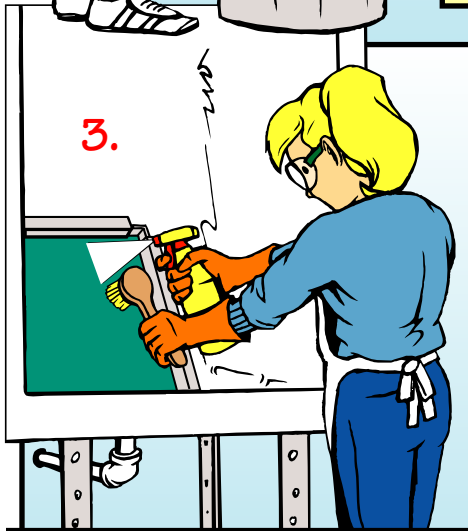

**3.**

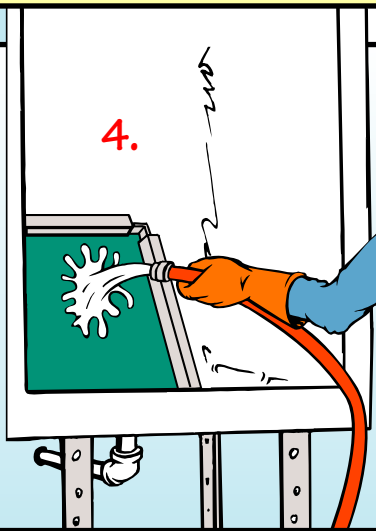

**4.**

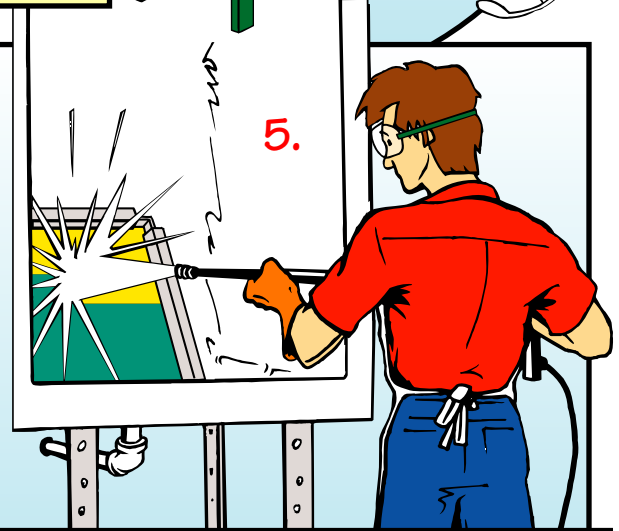

**5.**

**3. Reclaim the screens.** Squirt on an emulsion remover, scrub with your brush, and allow it to set for a few minutes. The remover will start to break up the emulsion. Don't let it dry! (If it is allowed to dry, it will never come off.) **4. Rinse off the remover.** Rinse off as much of the loose emulsion and remover from the screen as possible to prevent the chemicals from falling back on you. **5. Blast off the emulsion.** Use the pressure sprayer set on "fan spray" to blast off the remaining old emulsion. Overlap the spray on each pass to remove every last speck of old emulsion

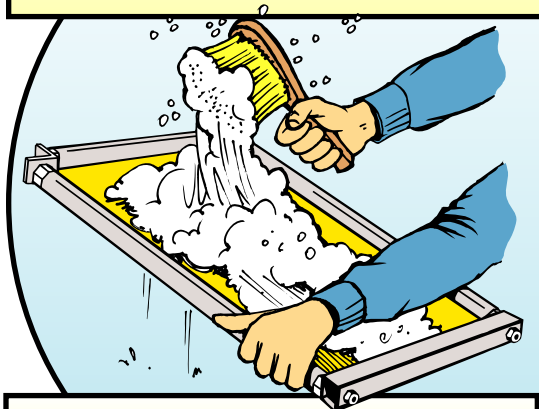

**6. Now, degrease again.** Once again, lather up, rinse, and dry the screens. Now you're all ready for the next job.

**Well, that's the end of our illustrated introduction.**

We told you it wouldn't be as bad as you first thought. Keep in mind, there are lots of smaller details to each step. Be sure to check out our website [www.VASTEX.com](http://www.VASTEX.com) for articles, more info, links, and tips. Additionally, there will be more information available as we add detailed chapters to this illustrated manual. Questions? We'd love to help. Call 1-800-482-7839 or e-mail us at [info@VASTEX.com](mailto:info@VASTEX.com) You'll soon discover the rewards (and profits!) in the craft and science of screen printing.

