



# V-1000 Printer

## Assembly and Operations Manual

### Floor and Tabletop Models



Tabletop press shown  
on optional utility cart

This manual contains the following documents:

- Introduction / Safety / Features Pg. 2
- Contents of boxes Pg. 3
- Component Identification Pg. 4
- Print Head Pg. 5
- Assembly Instructions Pg. 6-11
- Pallet Leveling Pg. 12
- Print Head Leveling Pg. 13
- Warranty / Terms & Conditions Pg. 14-16

Vastex International, Inc.  
1032 N. Irving St.  
Allentown, Pa. 18109 USA  
Phone# 610 434-6004 Fax# 610 434-6607  
Web Site [www.vastex.com](http://www.vastex.com)  
E-Mail [info@vastex.com](mailto:info@vastex.com)

## **Introduction**

---

**Thank you** for purchasing your printing equipment from Vastex International Inc.

Vastex has been designing and building printing equipment since 1960. We have knowledge and experience, and are proud to supply the printing industry with quality equipment at an affordable price. You can be confident your purchase will give you years of trouble free service.

## **Safety**

---

- The operator should read and understand this manual before operating this equipment. Store manual and safety information near equipment for easy access to operators.
- Keep children and pets clear of the work area.
- Do not sit or stand on printer
- The print heads utilize heavy duty springs to hold the screen in the raised position. These springs generate a lot of force. Care must be taken when installing and removing the print head lifting springs.
- Do not operate printer without print head stop bar in place.
- Do not allow print heads to swing into their raised position unrestrained.
- Screens should be installed and removed with print heads in their raised position.
- Print heads should remain in their raised position when not in use.

## **Features**

---

- Steel Pallets w/rubber top
- Floating Print heads allows multiple heads down
- Micro Registration
- 6 way head leveling
- Available up to 4 table 6 color
- Accurate multicolor registration
- Expandable from 1x1 to 4x6
- 3 year warranty on manufactures defects
- HD Head upgrade available

## **Tools Required**

---

- 1/4", 7/16", 1/2", 9/16" Wrench, Adjustable Wrench,
- 9/16 socket, ratchet and extension, level
- 3/4 Wrench (req. for optional service pan)

# Contents of Boxes

Your Printer has been packaged in several pre marked boxes. The printer you ordered may consist of several combinations of the following boxes.

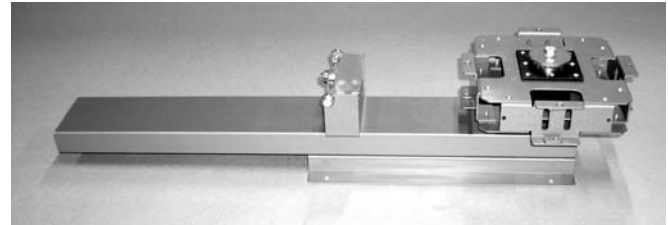
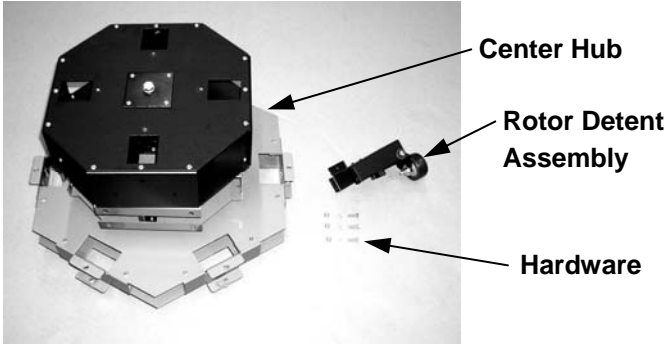

Tabletop Printer Assembly

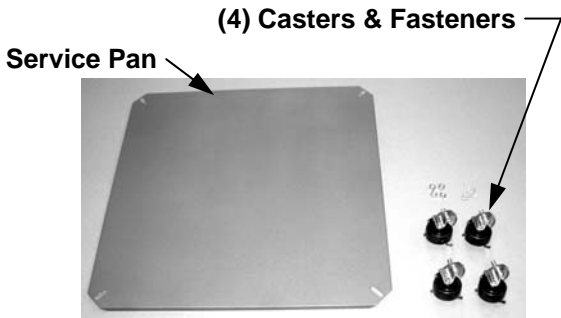
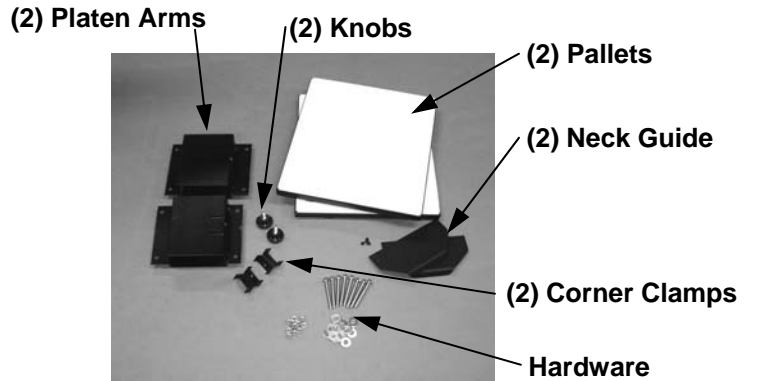
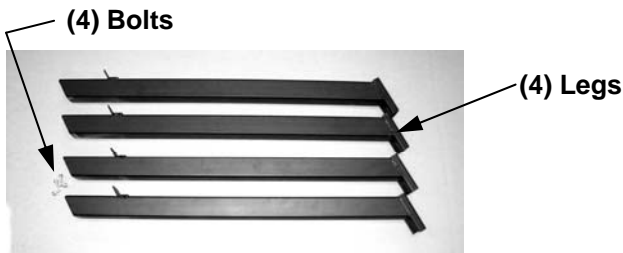

(optional for floor model only)

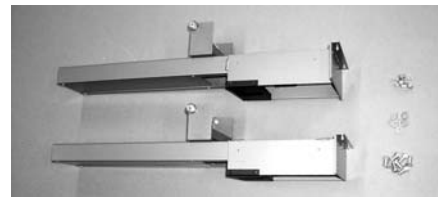

(2) Rotor Arms & Hardware

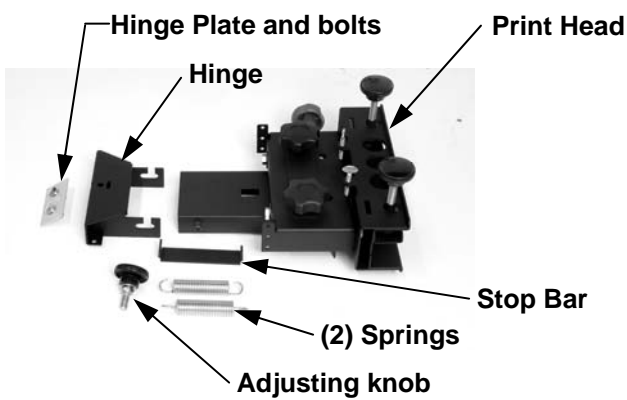

Standard Print Head

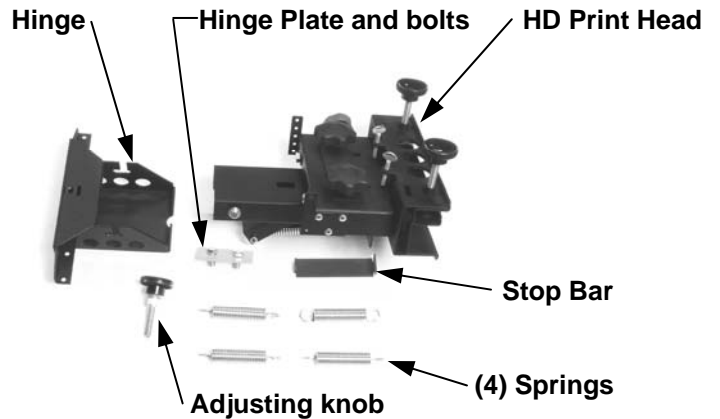

HD Print Head

## V-1000 4 Station 6 Color Press

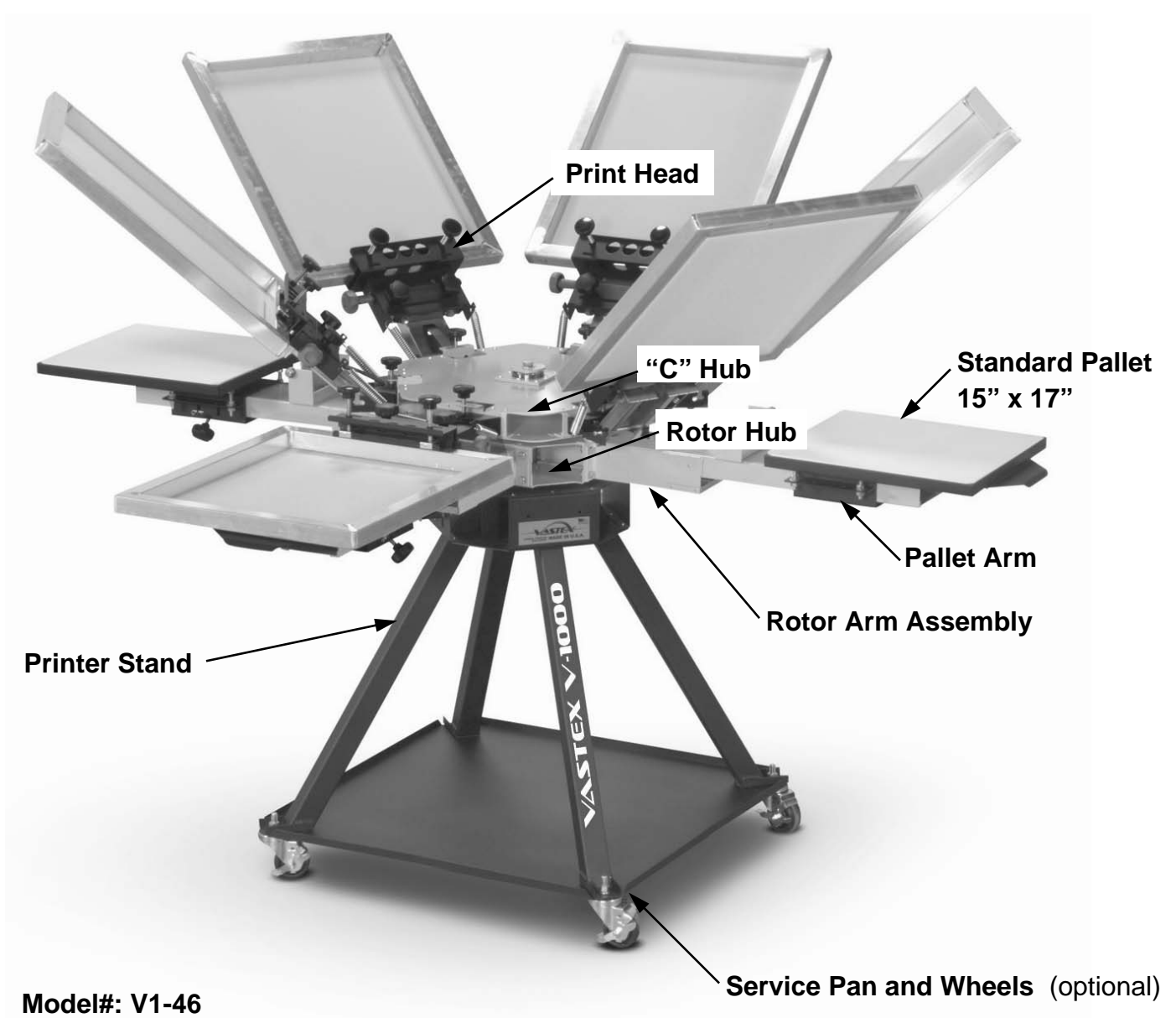

Model#: V1-46

(shown with Service Pan and Wheels )

## Print Head

### Print Head Overview:

The V-1000 Printers utilize floating print heads. When the print heads are lowered they lock into a Wheel Lock Housing. This effectively disengages the print head from the "C" hub and precisely aligns it to the pallet. The floating print head will only function properly if screens are set with off contact from pallets.

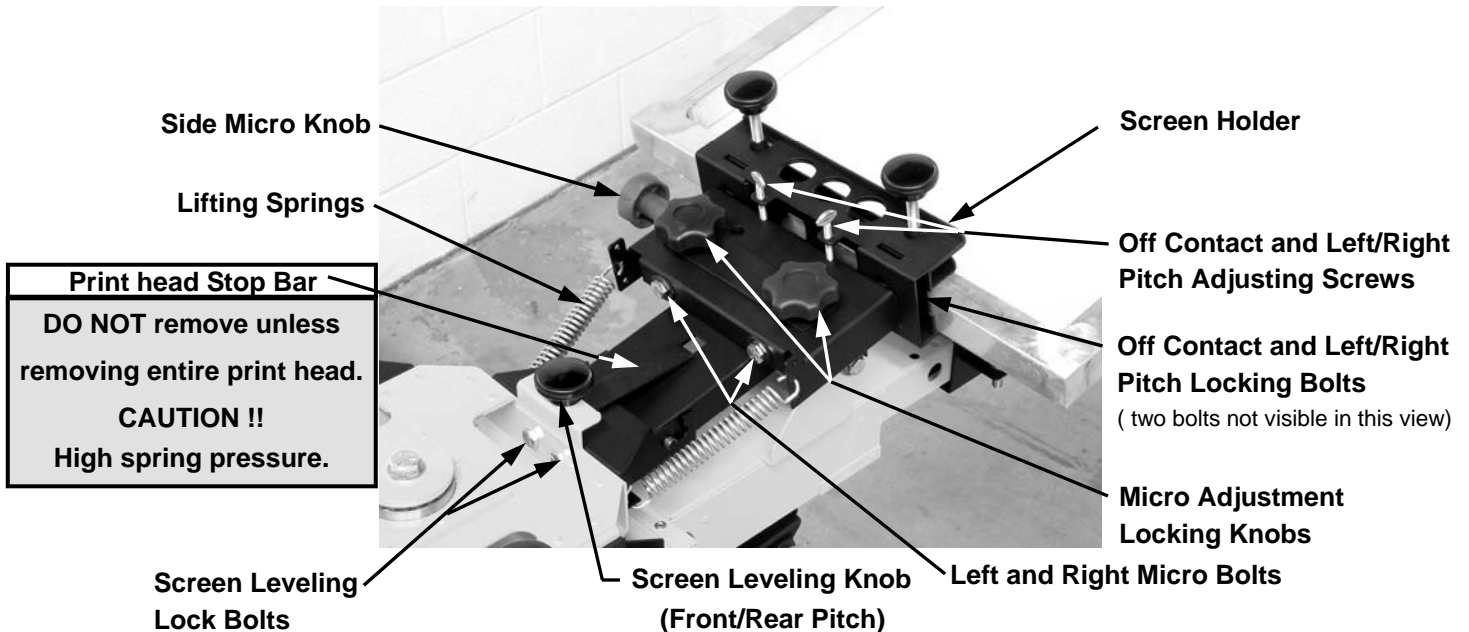

- **Screen Leveling Lock Bolts:** These bolts must be loosened to adjust the front to rear pitch. Tighten fully after pitch is adjusted. Be sure to push down on the print head when tightening to seat the print head into Wheel Lock Housing.
- **Screen Leveling Knob:** After loosening the Screen Leveling Lock Bolts, turn knob clockwise to pitch the front of the screen up, and counter-clockwise to pitch the front of the screen down.
- **Print Head Stop Bar:** DO NOT remove unless removing entire print head. This bar stops the Print Heads in the up position
- **Lifting Springs:** The coil springs hold the Print Head up, and pull tension for the micro adjustments.
- **Micro Adjustment Locking Knobs:** are loosened slightly when making micro adjustments. Retighten after adjustments are made.
- **Side Micro Knob:** (red) Controls side to side micro adjustment.
- **Left & Right Micro Bolts:** Rotates the screen several degrees in either direction and moves screen front to back.
- **Off Contact Locking Bolts:** Must be loosened slightly to make Off Contact adjustments.
- **Off Contact Adjusting Screws:** Used to level and set the distance between the screen and pallet.

**Note: For Micro Registration, loosen slightly the Micro Adjustment Locking Knobs before making screen adjustments. Check that locking knobs are tight before setting off contact.**

# Assembly

Tabletop models skip to page 8.

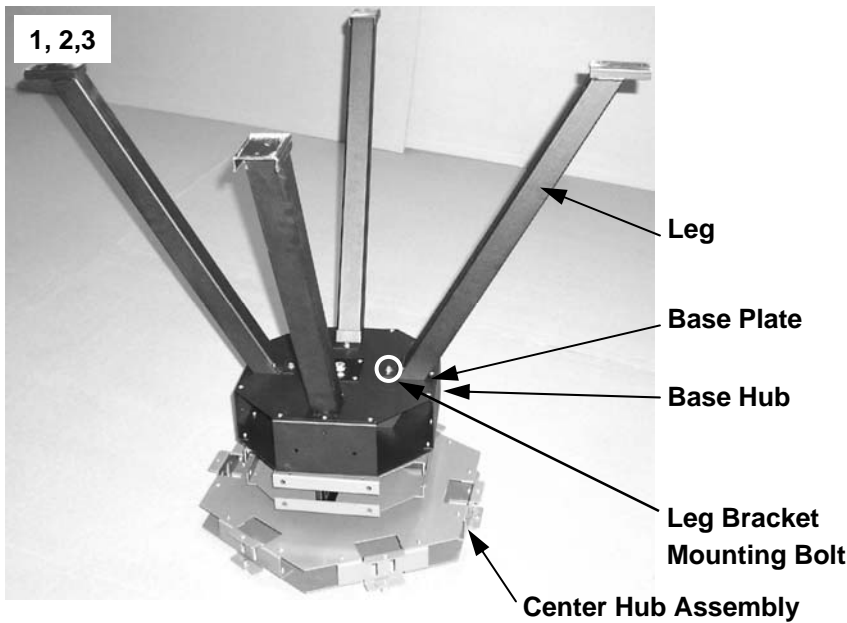

- 1) Place box marked Center Hub Assembly in an open area of your shop floor. Remove top of box. Center Hub assembly can remain in the box while installing legs and optional service pan.
- 2) Insert a leg through both rectangular openings in the upper and lower base plates of the base hub. Angled mounting bracket on leg should now be laying flat against the base plate. Insert  $5/16 \times 3/4$  lg. bolt through the angled mounting bracket and into base plate. Tighten bolt with  $1/2$ " wrench.
- 3) Install remaining legs. Make sure all bolts are tight.

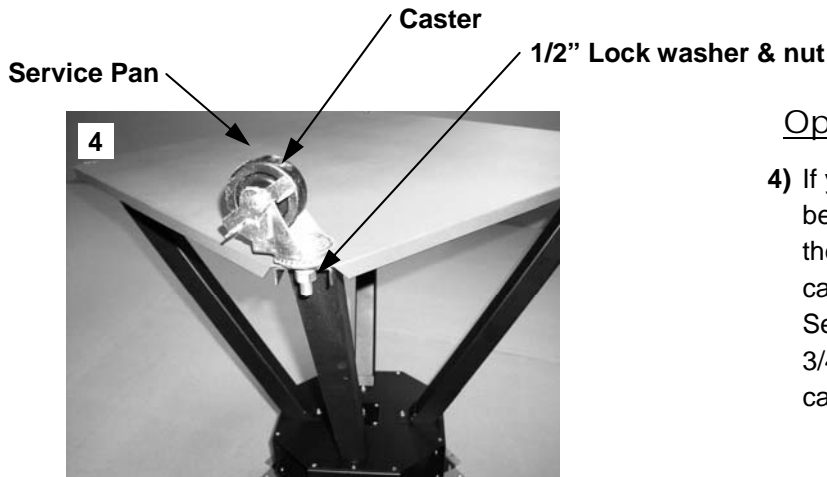

## Optional Service Pan and Wheels

- 4) If you ordered the optional service pan it should be installed next. Lay service pan on legs with the lip facing down, as shown at the left. Insert casters through slotted hole of pan and into leg. Secure with  $1/2$ " lock washers and hex nuts,  $3/4$ " wrench is required. Turn lever on side of caster wheels to the locked position.

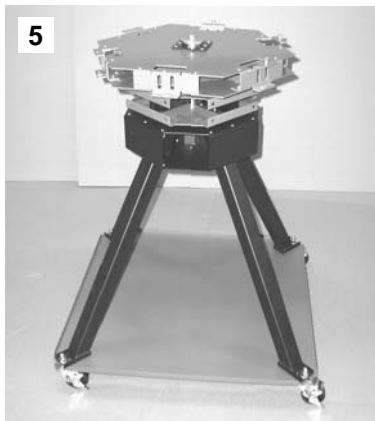

- 5) If casters have been installed, make certain they are in their locked position. Carefully turn printer up onto its legs or casters. With the printer in its upright position, slightly loosen the screws attaching the four legs to the base and if installed, all four caster locking nuts. This will allow the printer legs to settle into their final position. Retighten leg mounting screws and caster lock nuts.

## Assembly cont'd

- 6) Install the Rotor Detent Assembly using three 1/4" x 3/4" bolts, lock washers, and nuts using a 7/16" wrench. Install the assembly on any one of the four sides of the Base Hub. Once you have Rotor Arms installed, as described later in the manual, adjust the detent roller up or down to desired holding force. A 9/16" and adjustable wrench is required.

Base Hub Face Plate

Rotor Detent Assembly

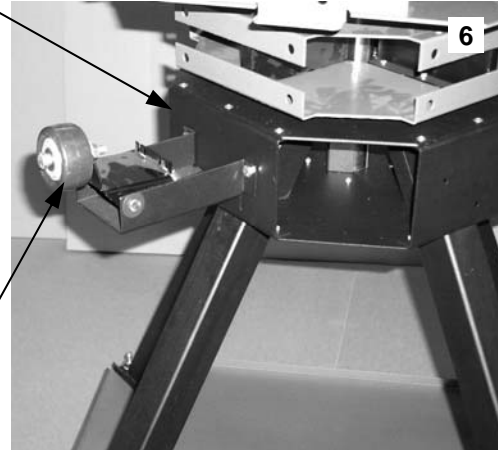

- 7) Install the Wheel Lock Housings onto the rotor arms. There are two mounting locations (shown on right). Select the correct set of holes for your printer, four or less, or six print heads. Attach wheel lock housings to rotors arm with four 3/8" x 3/4" bolts and square nuts, 9/16" socket and ratchet required. The square nuts are installed under the Rotor Arm, and will not spin while tightening the bolt.

6 Print Heads      4 (or less) Print Heads

Wheel Lock Housing

\*Wheel lock housing pictured may differ from included part. Mounting and function remain the same.\*

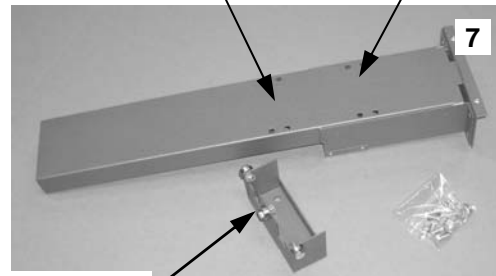

- 8) The Rotor Arms have Hook Pins. Place the rotor arm assembly against face of rotor hub and align pins to holes in top surface of rotor hub plate. Rotor arm is now supported by the Hook Pins. Secure Rotor Arm to hub with four 3/8 x 1" lg. bolts, lock washers, and nuts. Two 9/16" wrenches are required. Continue with installation of remaining Rotor Arms.

Wheel Lock Housing      Rotor Hub

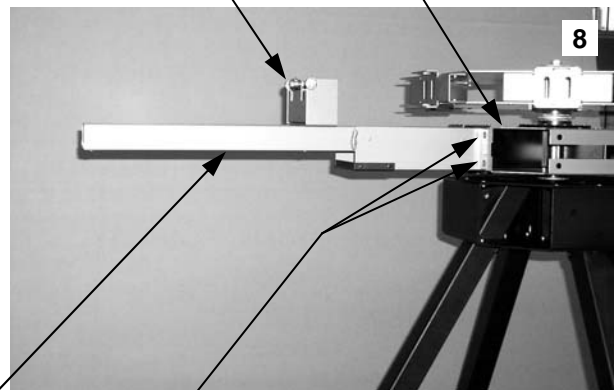

Rotor Arm      (4) 3/8 bolts, lock washers, & hex nuts

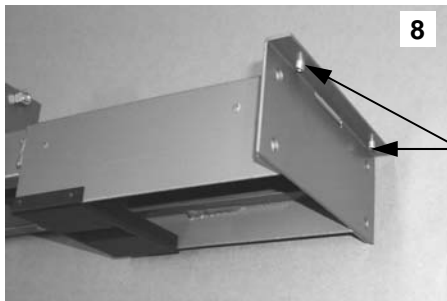

Hook Pins

## Assembly cont'd

Next step is the installation of the Hinge, Extension Arm, and Print Head. There are two available Print Heads for the V-1000. Both are installed in the same manor, only differing in number of springs and a Kickstand.

- The Standard Print Head, pictured below on the left, has a single pair of springs used for lifting and holding the Print Head.
- The HD Print Head, pictured below on the right, can have 4 springs at once, as well as a spring loaded Kick stand. The HD Print Head can be used with either 2 springs and the Kickstand, or 4 springs and the Kickstand.

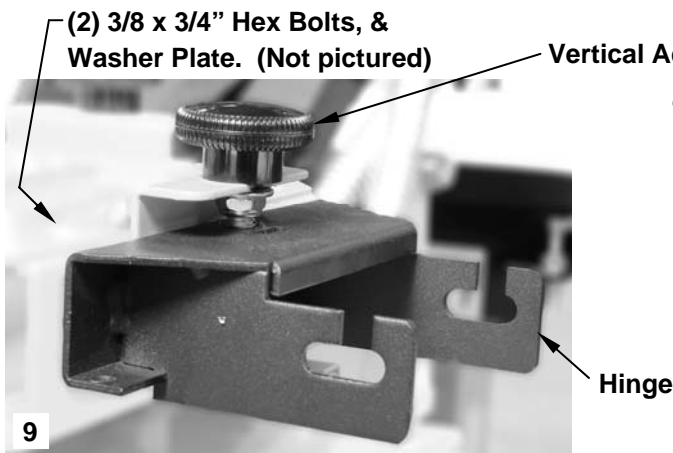
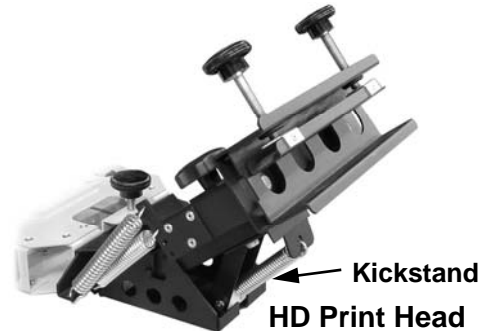

- 9) The Vertical Adjusting Knob has a pre-installed nut and washer. Screw the knob into the hinge leaving about 3/8" under the nut. Install the Hinge to the "C" hub face plate. Be sure that the washer and the nut are below the flange on the "C" hub face (as shown on left). Use two 3/8 x 3/4" bolts and one washer plate to attach the hinge to the "C" hub. Install all Hinges onto the press at this time.

**Caution must be taken when installing springs due to the great force they exert when extended.**

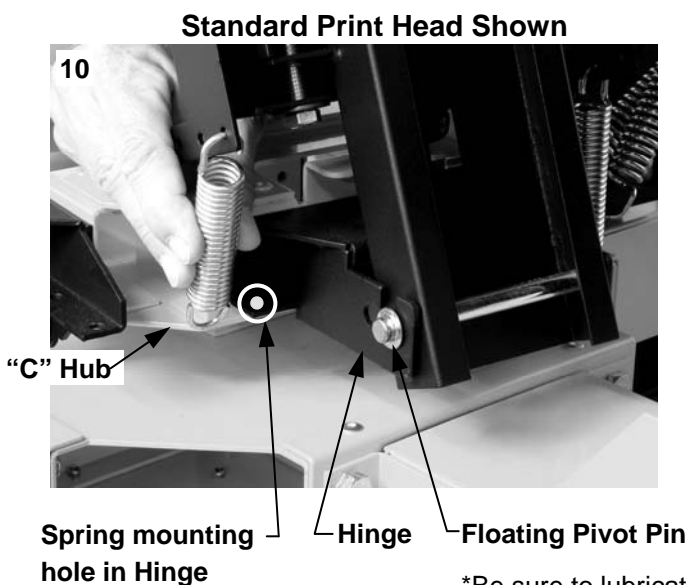

- 10) The print heads are shipped fully assembled. They need to be installed onto the Hinge. The print heads are held in the raised position with two springs. The first step is to insert both springs into their mounting holes on the print head. Always mount springs from the outside in. Choose lower holes for wood or aluminum screens, upper holes for roller frames. Insert the Floating Pivot Pin on the Head into the slot on the Hinge. While tilting the Head back, hook the springs into the Spring mounting hole in hinge as shown on left

**HD Head users:** Follow the same instructions for wood and aluminum frames. You will use the middle spring position on the Print Head with the inner position on the Hinge. If using oversized frames or the DiGiT, refer to **step 11**.

\*Be sure to lubricate the pivot pin where it contacts the hinge plate. \*



## Assembly cont'd

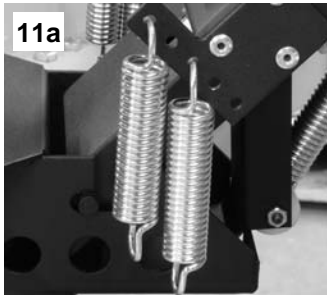

### Step 11 for HD Print Head Only

- 11a)** If installing the springs for the DiGit Number System or side clamps with roller frames, use the upper and middle spring mounting holes. Always hook springs from the outside in (pictured). Remove the upper spring from each side when using wood or aluminum screens.

**Caution must be taken when installing springs due to the great force they exert when extended.**

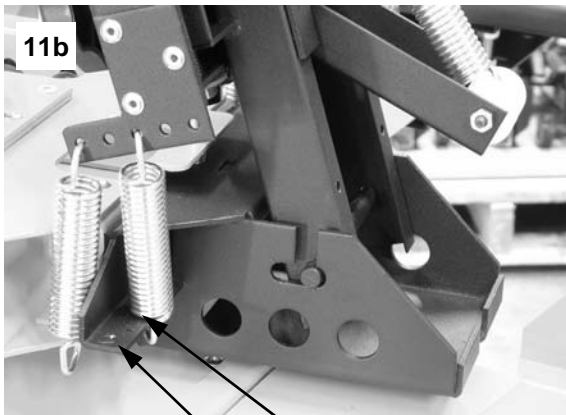

- 11b)** Tilt the entire assembly back and install the bottom spring (on both sides) into the inner holes on Hinge. Then install the top springs into the outer holes.

**Be sure all 4 springs are seated in their holes before moving on.**

**Inner Holes** Install First

**Outer Holes** Install Second

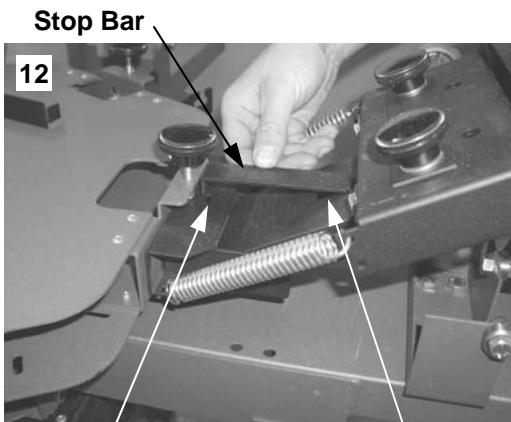

**Slot in hinge plate**

**Rectangular cutout**

- 12)** Lower the print head down over a pallet while insuring all springs stay seated correctly. Once fully in the down position, install the Stop Bar into the slots as shown on the left. The Stop Bar can only be installed one way. It is now safe to raise and lower the print head.

**Do Not allow the print head to swing into its raised position unrestrained.**

**\*Install all print heads at this time.\***

## Assembly cont'd

- 13) The Neck Guide attaches to the end of the pallet and aids in the loading of shirts onto pallet. Place pallet, rubber side down on a flat protected surface. If installing the neck guide, slide it into the end of the pallet and secure with two sheet metal screws using a 1/4" wrench. Be careful not to over tighten or cross thread the screws! **Note:** neck guide is needed if using Vastex Jacket Quick Stretch.

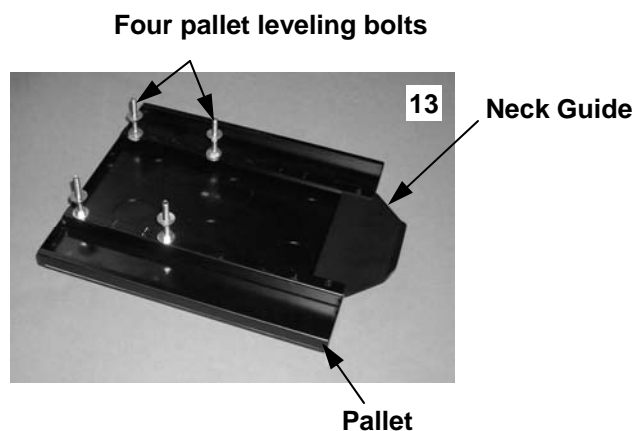

- 14) Place two washers onto each 3/8 x 3"lg. hex. bolt. Thread nuts to within 1/4" of bolt head. Slide bolts into open ended slots on bottom of pallet. Use the slots closest to the end of the pallet and 5-1/2" to next bolt. One washer must be on each side of slot. Tighten the nuts using two 9/16" open end wrenches, making certain bolts are all the way in their slots. Thread a nut approximately half way onto each bolt as shown on the right.

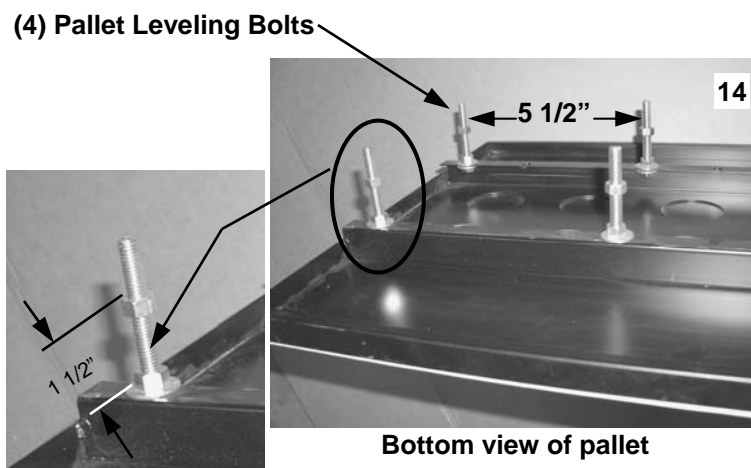

- 15) The Pallet Arm supports the pallets. Thread a Knob into each Pallet Arm and position Corner Clamp into slots in Pallet Arm. Install Hair Pin to hold the Corner Clamp into the Pallet Arm.

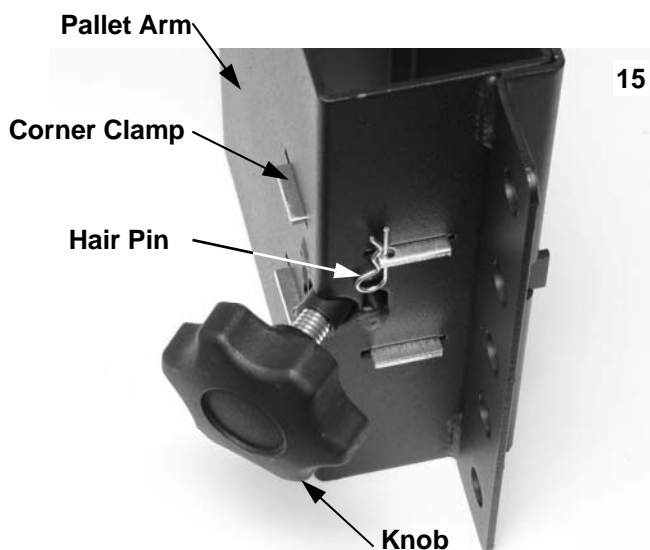

## Assembly cont'd

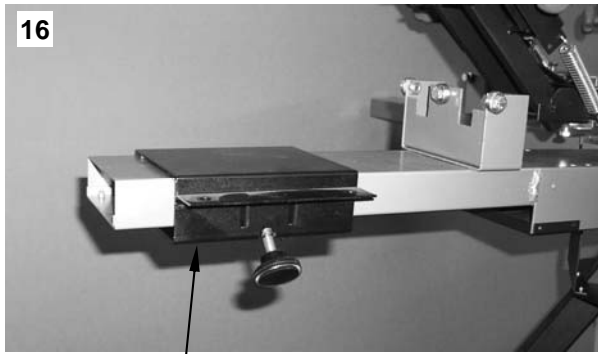

Pallet arm installed on rotor arm

- 16) Slide the pallet arm over the rotor arm and tighten the corner clamp knob.

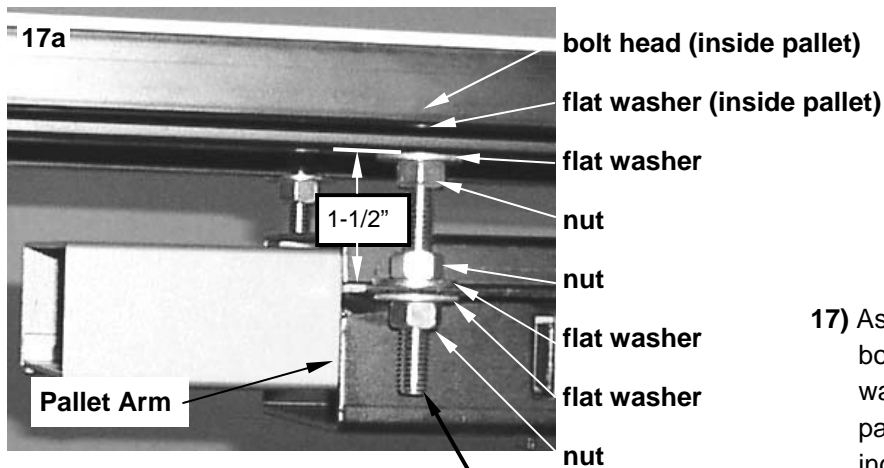

- 17) Assemble the pallets with the pre-installed bolts onto the pallet arms. Position flat washers over the four corner holes in the pallet arm and insert the pallet with leveling bolts. Install one flat washer and one nut onto each bolt. Only hand tighten at this time.

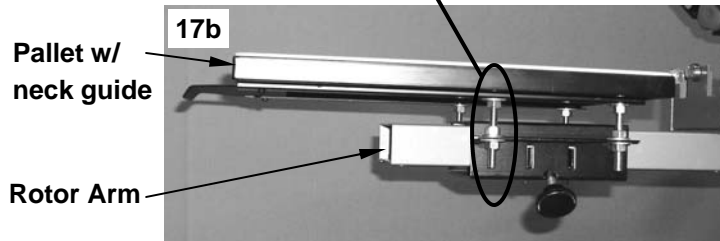

# Pallet Leveling

Note: Level only one pallet with the following procedure and mark this pallet as #1. Then level all print heads to this pallet. See Print Head Leveling for instructions.

- 18) First, tighten the pallet arm locking knob. Take a reading from a level placed on the bottom of the pallet arm.

Pallet Adjusting Nuts

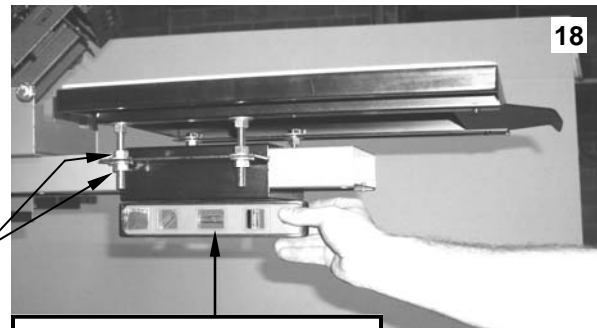

- 19) Move the level to the top of the pallet towards one side. Adjust the pallet to match the reading taken from pallet arm. Move the level to the opposite side and adjust to the pallet arm reading. Recheck both sides after making adjustments.

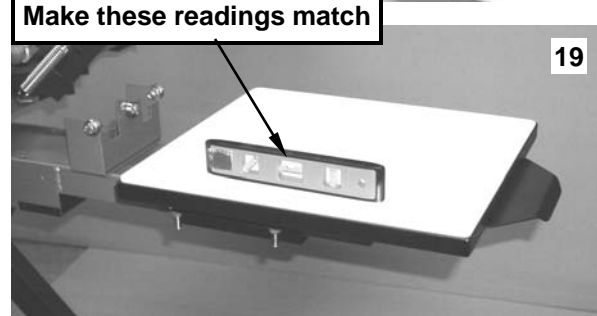

- 20) Turn level and take a reading on the pallet arm in the other direction.

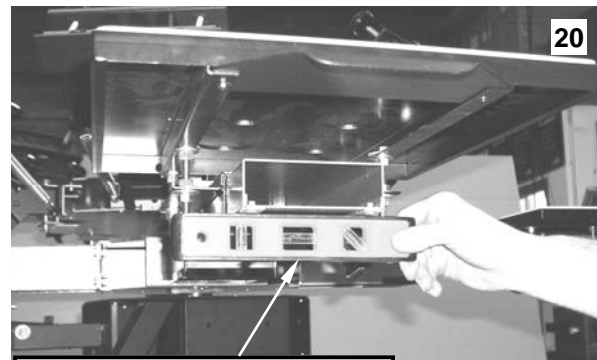

- 21) Move the level to the top of the pallet towards one side. Adjust the pallet to match the reading taken from pallet arm. Move level to the opposite side and adjust to the pallet arm reading. Recheck both sides after making adjustments.

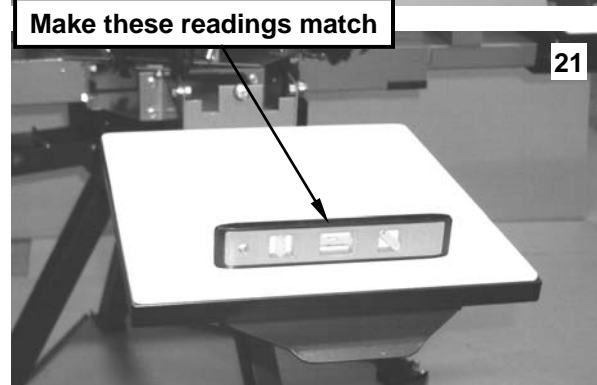

Note: Recheck level readings in all directions throughout the leveling process. After the pallet is level to the pallet arm, tighten all nuts.

An Improperly leveled pallet may not be flat. Loosen the bolts and re-level the pallet to eliminate any possible warping of the pallet.

# Print Head Leveling

Please review Print Head overview to better understand all adjustments.

- 22) Level a Print Head to the #1 pallet. Check that the screen holder is midway in the vertical adjusting slots. Clamp a flat screen in place. Lower the screen and loosen both Screen Leveling Lock bolts approximately 1/2 turn. Be sure to push down firmly on the print head above the Wheel Lock Housing while turning the Screen Leveling Knob. Adjust the screen parallel to pallet front to back. Evenly tighten both lock bolts when the screen is parallel to the pallet, be sure to push down on the head to keep the bearings evenly engaged while tightening.
- 23) After setting the front to back parallel to the #1 pallet, adjust the screen to be parallel left to right. Loosen the Adjusting Bolts for the screen holder about 1/4 turn, using a 9/16" open end wrench. Turn the Off Contact and Left/Right Pitch Adjusting Screws one at a time to set the left/right pitch and off contact amount. You can place spacers on the screen, such as a wooden paint stirrer, to use as a reference to set your off contact and left/right pitch.

Repeat steps 22 & 23 for all Print Heads.

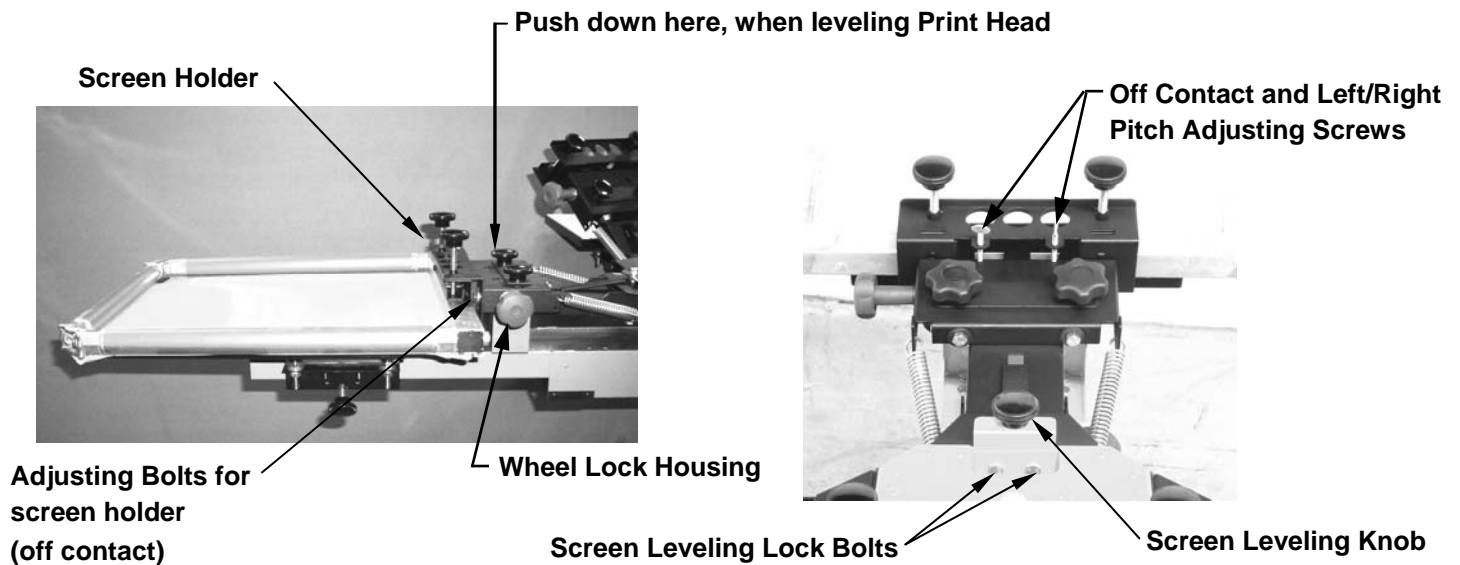

At this point one pallet has been leveled to its rotor arm and all print heads have been leveled to this pallet. Now we want to adjust the remaining pallets to the leveled print heads while centering the pallets over the rotor arms.

- 24) Insert a flat screen into a print head and align the edge of the screen with the edge of the pallet. Adjust all remaining pallets parallel to the bottom of the screen, as described in steps 21 and 22, and flush with the edge of this screen. Maintain a consistent gap between screen and pallets.

Align side of screen with side of pallet



Your Vastex Printer is now ready for printing shirts.

# **Vastex Warranty**

Doc#01-00-005B Revised 10/15/07

(1.) Vastex, hereinafter referred to as “seller” warrants only to its original “purchaser”, who holds a copy of the original invoice and is the original end user of the equipment in question, its new equipment against defects in materials or workmanship on a pro-rated basis. Warranty period begins from date of shipment to the buyer and will only apply to customers paid in full. Warranty periods are as follows: one (1) year for E-1000, and V-1000, three (3) years for all other equipment (including F-Flash), ten (10) years for infrared heaters (excluding F-Flash) installed by Vastex in a new dryer, three (3) years for replacement infrared heaters, and one (1) year for replacement parts. Rubber blankets, light bulbs and glass on exposure units are particularly subject to wear while in use. Wear is not covered by this warranty but as stated above only manufacturers defects are covered. All sales made through Vastex dealers must be certified by that dealer before a warranty replacement is issued.

**(2.) This warranty is expressly contingent upon the buyer delivering to seller, at the address below, with all transportation charges prepaid, the part or parts claimed to be defective within the above mentioned warranty periods stated in paragraph one. The defective part or parts will be repaired or replaced at the discretion of Vastex International, Inc. If the equipment in question is less than one (1) year old, it will be shipped to the customer at no charge, with an RGA issued by Vastex for the defective part. The defective part must be shipped back to Vastex freight prepaid within 30 days or the account will be billed. If the equipment is more than a year old, the part will be shipped after we receive the defective part. If it's necessary to expedite the movement of parts and to minimize down time to the buyer, the replacement part shall be supplied on a C.O.D. basis. If testing and analysis of said part by the seller or its supplier discloses that said part is defective, the cost of said part will be refunded to the buyer on a prorated basis.**

(3.) Except as otherwise provided herein, the equipment is being sold “as-is”. Final determination of the suitability of the equipment for the use contemplated by the buyer, is the sole responsibility of buyer, and seller shall have no responsibility in connection with the suitability.

(4.) All warranties implied by law, including the implied warranties of merchantability and fitness are hereby limited to workmanship and defective parts to a warranty period stated in paragraph one. The express warranty and remedies contained herein and such implied limited warranties are made solely to the sole warranties and remedies and are in lieu of all other warranties, guarantees, agreements, and other liabilities, whether express or implied, and all other remedies for breach of warranty or any other liability of seller, in no event shall seller be liable for consequential damages.

No person, agent, distributor, or service representative is authorized to change, modify or extend the terms hereof in any manner whatsoever.

These terms and conditions are an essential part of the transaction between the parties and constitute the entire agreement between them with respect to the same.

Some states do not allow limitation on how long an implied warranty lasts of the exclusion or limitation of incidental, or consequential damages, so the above limitation may not apply to you.

This warranty gives you specific legal rights, and you may also have other rights which vary from state to state.

Infrared heaters are the only replacement parts covered for a period of (3) years from date of shipment and contingent to receipt of payment in full.

Electrical components can not be returned once installed unless proven defective.

Please refer to doc. 01-01-006 for warranty implementation help.

Please refer to doc. 01-00-015 for specific terms and conditions of sale and the limited warranty.

Please refer to doc. 01-00-017 for V-2000HD printer warranty.

F:\Shared\Vastex\01-Manuals & Doc\00-misc\01-00-005B\_Warranty.doc

# VASTEX WARRANTY IMPLEMENTATION SHEET

Please read this document in order to fully understand the warranty.

Doc.# 01-00-006

Your new Vastex equipment is protected against \*manufacturers' defects by our warranty, completely explained in doc# 01-00-017 for the V2000-HD series manual printer and in doc# 01-00-005 for all other Vastex manufactured equipment. Please refer to these documents for the \*\*warranty term and specific concerns about the warranty. The following are some important facts and requirements for the proper implementation of the warranty.

1.0 Everything is covered!

2.0 \*\*Warranty Term is defined as: Ship date from VASTEX to the date the item in question is returned to VASTEX for inspection and repair.

3.0 \*Manufacturers defects are defined as: Parts determined to be defective in workmanship which will lead up to a premature failure. The determination will be made only by the manufacturer of the item in question.

4.0 To take advantage of the warranty the following steps must be taken:

4.1 The equipment must be paid for in full.

4.2 The item in question must be shipped to VASTEX for evaluation with all shipping costs incurred by the buyer.

4.3 If the item is deemed as a manufacturer's defect it will be repaired or replaced within 2 business days from the time received. The shipping cost back to the customer located in the continental United States will be paid by VASTEX if a warranty item.

4.4 **If the item in question must be replaced immediately and is more than a year old, it will have to be purchased at list price and will be shipped COD. A pro-rated credit will be given promptly if the returned item is a valid manufacturer's defect.**

4.5 If the equipment was shipped less than a year before the date of the service call and a technician confirms the part needed for repair, the replacement will be shipped before the replacement is shipped back. An RGA will be issued and must accompany the old part to VASTEX within 30 days or the account will be billed.

5.0 Important facts about the condition of shipped equipment:

5.1 Dryers are partially assembled with the belts tracked and the machine run at full temperature for a min. of 1 ½ hours.

5.2 Printers are partially assembled, inspected, and adjusted for all heads down prior to partial disassembly and packing.

5.3 Exposing units are fully assembled and tested with the maximum screen size for vacuum integrity, timer operation and light output.

6.0 This document is in addition to the standard warranty and only helps the customer understand how to take advantage of the warranty. In no way does this document override the standard warranty or the terms and conditions of sale and the limited warranty doc# 01-00-015.

Please see doc# 01-00-015 for specific terms and conditions of sale and the limited warranty

VASTEX  
INTERNATIONAL

1032 N. IRVING ST.  
ALLENTOWN PA. 18109 USA

# Vastex International, Inc.

## TERMS AND CONDITIONS OF SALE AND LIMITED WARRANTY Doc.#01-00-015

1. Buyer's order will constitute an offer in accordance with the terms hereof and such offer, upon acknowledgment of Seller, will constitute the agreement between Buyer and Seller. Buyer's order after such acknowledgment by Seller will not be subject to cancellation, change or reduction in amount, or suspension by Buyer of deliveries, unless prior to such action Buyer has obtained Seller's written consent. Notwithstanding anything to the contrary in Buyer's Purchase Order or other communications, the parties agree to be bound by these Terms and Conditions. Acceptance of the product by the Buyer shall be deemed to constitute unconditional acceptance of these Terms and Conditions.

2. Any of these terms, conditions and provisions of Buyer's order which are inconsistent with Seller's acknowledgment and these Terms and Conditions of Sale shall not be binding on the Seller and shall be considered not applicable to any sale so made. No waiver, alteration or modification of any of the provisions on either side of the document shall be binding upon Seller unless agreed to in writing by Seller.

3. (a) All prices are F.O.B. Seller's Plant and method of delivery and routing shall be at Seller's discretion, unless specifically otherwise stated herein. Notwithstanding any agreement to pay freight, delivery of products purchased hereunder to a common carrier or licensed trucker shall constitute delivery to Buyer and be determinative of the date and time of shipment and all risk of loss or damage in transit shall be borne by Buyer. If the Buyer fails to accept the goods from the common carrier or licensed trucker, the Seller shall be entitled to claim payment from the Buyer. Seller shall arrange for storage, the risk and the cost, including insurance costs, to be borne by the Buyer (and Buyer agrees to pay such amounts upon demand) except if the failure to accept delivery is due to any of the exceptions noted in Paragraph 4.

(b) Terms of payment shall be as stated on invoice.

4. It is understood that deliveries will be made in accordance with Seller's regular production schedule. Every reasonable effort will be made to meet the Buyer's required delivery dates but Seller will not be liable for damages or be deemed to be in default by reason of any failure to deliver or delay in delivery due to any preference, priority, allocation or allotment order issued by the Government, whether Federal, State or local, or causes beyond its control including but not limited to, Acts of God or a public enemy, acts of Government, fires, floods, epidemics, quarantine restrictions, strikes, lockouts, freight embargoes, severe weather, unavailability of materials or shipping space, delays of carriers or suppliers or delays of any subcontractors. Should delay in delivery be caused by any of the circumstances mentioned in this paragraph, such extension of the delivery period shall be granted as is reasonable under the circumstances of the case. Should delay be caused by an event not specifically mentioned in this paragraph, damages will be limited to cancellation of the purchase order without penalty, and refund of any monies deposited or prepaid on the purchase order with no liability for any consequential or incidental damages.

5. Seller reserves the right to increase the prices prior to Seller's acceptance of order and/or after expiration of any price quoted by Seller.

6. Unless otherwise stated in writing, Seller's prices do not include sales, excise, value-added or other taxes. Consequently, in addition to the price specified herein, the amount of any present or future sales, use, excise, value-added or other tax applicable to the manufacture, sale, purchase or use of the products hereunder shall be paid by Buyer, or in lieu thereof, Buyer shall provide Seller with a valid tax exemption certificate acceptable to the taxing authorities.

7. Seller reserves the right, at any time, to revoke any credit extended to Buyer because of Buyer's failure to pay for any products when due or for any other reason deemed good and sufficient by Seller and in such event, all subsequent shipments shall be paid for prior to at delivery at Seller's option.

8. (a) SELLER'S LIABILITY SHALL BE LIMITED TO SELLER'S STATED SELLING PRICE PER UNIT OF ANY DEFECTIVE GOODS AND SHALL IN NO EVENT INCLUDE BUYER'S MANUFACTURING COSTS, LOST PROFITS, GOODWILL, OR ANY OTHER SPECIAL, INDIRECT, INCIDENTAL OR CONSEQUENTIAL DAMAGES, ARISING OUT OF THE AGREEMENT, THIS CONTRACT, THE SALE OF THE PRODUCTS TO THE BUYER OR THE USE OR THE PERFORMANCE OF THE PRODUCTS. Seller may at its discretion repair, replace or give the Buyer credit (pro-rated) for such defective products.

(b) Notwithstanding anything herein to the contrary, Seller shall have no liability for alleged defects with the products which are not specified in written notice from the Buyer to the Seller within thirty-six (36) months from the date of shipment of machines. Seller shall pass to Buyer any warranty received by Seller from the manufacturer of Limited Life Components, which in most cases is 12 to 18 months.

(c) Seller shall have no liability under this Limited Warranty unless Buyer has paid in full for the products. Further, this Limited Warranty is expressly contingent on Buyer's delivery to Seller, all costs prepaid, the defective part(s) within thirty-six (36) months of shipment to Buyer, together with a written statement specifying the alleged defect(s). Any replacement part(s) shall be shipped to Buyer on a C.O.D. basis.

(d) SELLER SPECIFICALLY EXCLUDES ALL WARRANTIES, EXPRESSED, IMPLIED OR OTHERWISE, EXCEPT AS STATED EXPLICITLY IN THESE TERMS AND CONDITIONS OF SALE. SELLER DISCLAIMS THE WARRANTY OF MERCHANTABILITY AND FITNESS FOR A PARTICULAR PURPOSE.

9. The remedies herein reserved by Seller shall be cumulative and in addition to any other legal remedies. No waiver of a breach of any portion of this contract shall constitute a waiver of continuing or future breach of such provision or of any other provisions hereof.

10. These Terms and Conditions constitute the entire agreement of the parties. No amendments, changes, revisions or discharges hereof in whole or in part shall have any force or effect unless set forth in writing and signed by the parties hereto. This contract shall not be assignable by Buyer voluntarily by operation of law or otherwise without Seller's written consent.

11. This contract shall be governed and shall be construed according to the domestic laws of the Commonwealth of Pennsylvania.

12. Anything herein to the contrary notwithstanding, any action for alleged breach by Seller of the contract between the parties, including but not limited to any action for breach of the warranties herein set forth, shall be barred unless commenced by Buyer within one (1) year from the date such cause of action accrued.

13. This agreement shall inure to the benefit of and be binding upon the parties hereto, their respective successors and permitted assigns.

14. **All notices required by this contract to be given by either party shall be sent in writing or by facsimile and shall be addressed to the last known address of such other party. Notices shall be deemed to have been received on the fifth business day following deposit in the mail.**